



Standard Test Method for Bearing Response of Polymer Matrix Composite Laminates¹

This standard is issued under the fixed designation D5961/D5961M; the number immediately following the designation indicates the year of original adoption or, in the case of revision, the year of last revision. A number in parentheses indicates the year of last reapproval. A superscript epsilon (ϵ) indicates an editorial change since the last revision or reapproval.

1. Scope

1.1 This test method covers the bearing response of pinned or fastened joints using multi-directional polymer matrix composite laminates reinforced by high-modulus fibers by double-shear tensile loading (Procedure A), single-shear tensile or compressive loading of a two-piece specimen (Procedure B), single-shear tensile loading of a one-piece specimen (Procedure C), or double-shear compressive loading (Procedure D). Standard specimen configurations using fixed values of test parameters are described for each procedure. However, when fully documented in the test report, a number of test parameters may be optionally varied. The composite material forms are limited to continuous-fiber or discontinuous-fiber (tape or fabric, or both) reinforced composites for which the laminate is balanced and symmetric with respect to the test direction. The range of acceptable test laminates and thicknesses are described in 8.2.1.

1.2 This test method is consistent with the recommendations of MIL-HDBK-17, which describes the desirable attributes of a bearing response test method.

1.3 The multi-fastener test configurations described in this test method are similar to those used by industry to investigate the bypass portion of the bearing bypass interaction response for bolted joints, where the specimen may produce either a bearing failure mode or a bypass failure mode. Note that the scope of this test method is limited to bearing and fastener failure modes. Use Test Method D7248/D7248M for by-pass testing.

1.4 The values stated in either SI units or inch-pound units are to be regarded separately as standard. The values stated in each system may not be exact equivalents; therefore, each system shall be used independently of the other. Combining values from the two systems may result in non-conformance with the standard.

1.4.1 Within the text the inch-pound units are shown in brackets.

1.5 *This standard does not purport to address all of the safety concerns, if any, associated with its use. It is the responsibility of the user of this standard to establish appropriate safety and health practices and determine the applicability of regulatory limitations prior to use.*

2. Referenced Documents

2.1 ASTM Standards:²

- D792 Test Methods for Density and Specific Gravity (Relative Density) of Plastics by Displacement
- D883 Terminology Relating to Plastics
- D953 Test Method for Bearing Strength of Plastics
- D2584 Test Method for Ignition Loss of Cured Reinforced Resins
- D2734 Test Methods for Void Content of Reinforced Plastics
- D3171 Test Methods for Constituent Content of Composite Materials
- D3410/D3410M Test Method for Compressive Properties of Polymer Matrix Composite Materials with Unsupported Gage Section by Shear Loading
- D3878 Terminology for Composite Materials
- D5229/D5229M Test Method for Moisture Absorption Properties and Equilibrium Conditioning of Polymer Matrix Composite Materials
- D5687/D5687M Guide for Preparation of Flat Composite Panels with Processing Guidelines for Specimen Preparation
- D7248/D7248M Test Method for Bearing/Bypass Interaction Response of Polymer Matrix Composite Laminates Using 2-Fastener Specimens
- E4 Practices for Force Verification of Testing Machines
- E6 Terminology Relating to Methods of Mechanical Testing
- E83 Practice for Verification and Classification of Extensometer Systems
- E122 Practice for Calculating Sample Size to Estimate, With Specified Precision, the Average for a Characteristic of a Lot or Process
- E177 Practice for Use of the Terms Precision and Bias in ASTM Test Methods

¹ This test method is under the jurisdiction of ASTM Committee D30 on Composite Materials and is the direct responsibility of Subcommittee D30.05 on Structural Test Methods.

Current edition approved May 1, 2013. Published June 2013. Originally approved in 1996. Last previous edition approved in 2010 as D5961/D5961M – 10. DOI: 10.1520/D5961_D5961M-13.

² For referenced ASTM standards, visit the ASTM website, www.astm.org, or contact ASTM Customer Service at service@astm.org. For *Annual Book of ASTM Standards* volume information, refer to the standard's Document Summary page on the ASTM website.

E238 Test Method for Pin-Type Bearing Test of Metallic Materials

E456 Terminology Relating to Quality and Statistics

E691 Practice for Conducting an Interlaboratory Study to Determine the Precision of a Test Method

E1309 Guide for Identification of Fiber-Reinforced Polymer-Matrix Composite Materials in Databases (Withdrawn 2015)³

E1434 Guide for Recording Mechanical Test Data of Fiber-Reinforced Composite Materials in Databases (Withdrawn 2015)³

E1471 Guide for Identification of Fibers, Fillers, and Core Materials in Computerized Material Property Databases (Withdrawn 2015)³

2.2 Other Document:

MIL-HDBK-17, *Polymer Matrix Composites*, Vol 1, Section 7⁴

3. Terminology

3.1 *Definitions*—Terminology **D3878** defines terms relating to high-modulus fibers and their composites. Terminology **D883** defines terms relating to plastics. Terminology **E6** defines terms relating to mechanical testing. Terminology **E456** and Practice **E177** define terms relating to statistics. In the event of a conflict between terms, Terminology **D3878** shall have precedence over the other documents.

NOTE 1—If the term represents a physical quantity, its analytical dimensions are stated immediately following the term (or letter symbol) in fundamental dimension form, using the following ASTM standard symbology for fundamental dimensions, shown within square brackets: $[M]$ for mass, $[L]$ for length, $[T]$ for time, $[I]$ for thermodynamic temperature, and $[nd]$ for nondimensional quantities. Use of these symbols is restricted to analytical dimensions when used with square brackets, as the symbols may have other definitions when used without the brackets.

3.2 *Definitions of Terms Specific to This Standard:*

3.2.1 *bearing area*, $[L^2]$, n —the area of that portion of a bearing specimen used to normalize applied loading into an effective bearing stress; equal to the diameter of the loaded hole multiplied by the thickness of the specimen.

3.2.2 *bearing chord stiffness*, $E^{br} [ML^{-1}T^{-2}]$, n —the chord stiffness between two specific bearing stress or bearing strain points in the linear portion of the bearing stress/bearing strain curve.

3.2.3 *bearing force*, $P [MLT^{-2}]$, n —the total force carried by a bearing specimen.

3.2.4 *bearing strain*, $\epsilon^{br} [nd]$, n —the normalized hole deformation in a bearing specimen, equal to the deformation of the bearing hole in the direction of the bearing force, divided by the diameter of the hole.

3.2.5 *bearing strength*, $F_x^{br} [ML^{-1}T^{-2}]$, n —the value of bearing stress occurring at a significant event on the bearing stress/bearing strain curve.

³The last approved version of this historical standard is referenced on www.astm.org.

⁴Available from Standardization Documents Order Desk, DODSSP, Bldg. 4, Section D, 700 Robbins Ave., Philadelphia, PA 19111-5098, <http://dodssp.daps.dla.mil>.

3.2.5.1 *Discussion*—Two types of bearing strengths are commonly identified, and noted by an additional superscript: offset strength and ultimate strength.

3.2.6 *bearing stress*, $F^{br} [ML^{-1}T^{-2}]$, n —the bearing force divided by the bearing area.

3.2.7 *countersink depth to thickness ratio*, $d_{csk}/h [nd]$,—the ratio of the countersunk depth of a hole to the specimen thickness.

3.2.7.1 *Discussion*—The countersink depth to thickness ratio is typically a nominal value determined from nominal hole-drilling dimensions and tolerances.

3.2.8 *diameter to thickness ratio*, $D/h [nd]$, n —in a bearing specimen, the ratio of the hole diameter to the specimen thickness.

3.2.8.1 *Discussion*—The diameter to thickness ratio may be either a nominal value determined from nominal dimensions or an actual value determined from measured dimensions.

3.2.9 *edge distance ratio*, $e/D [nd]$, n —in a bearing specimen, the ratio of the distance between the center of the hole and the specimen end to the hole diameter.

3.2.9.1 *Discussion*—The edge distance ratio may be either a nominal value determined from nominal dimensions or an actual value determined from measured dimensions.

3.2.10 *nominal value*, n —a value, existing in name only, assigned to a measurable quantity for the purpose of convenient designation. Tolerances may be applied to a nominal value to define an acceptable range for the quantity.

3.2.11 *offset bearing strength*, $F_x^{bro} [ML^{-1}T^{-2}]$, n —the value of bearing stress, in the direction specified by the subscript, at the point where a bearing chord stiffness line, offset along the bearing strain axis by a specified bearing strain value, intersects the bearing stress/bearing strain curve.

3.2.11.1 *Discussion*—Unless otherwise specified, an offset bearing strain of 2 % is to be used in this test method.

3.2.12 *width to diameter ratio*, $w/D [nd]$, n —in a bearing specimen, the ratio of specimen width to hole diameter.

3.2.12.1 *Discussion*—The width to diameter ratio may be either a nominal value determined from nominal dimensions or an actual value, determined as the ratio of the actual specimen width to the actual hole diameter.

3.2.13 *ultimate bearing strength*, $F_x^{bru} [ML^{-1}T^{-2}]$, n —the value of bearing stress, in the direction specified by the subscript, at the maximum force capability of a bearing specimen.

3.3 *Symbols:*

A = minimum cross-sectional area of a specimen

CV = coefficient of variation statistic of a sample population for a given property (in percent)

d = fastener or pin diameter

D = specimen hole diameter

d_{csk} = countersink depth

d_{fl} = countersink flushness (depth or protrusion of the fastener in a countersunk hole)

e = distance, parallel to force, from hole center to end of specimen; the edge distance

E_x^{br} = bearing chord stiffness in the test direction specified by the subscript (for determination of offset bearing strength)
 f = distance, parallel to force, from hole edge to end of specimen

F_x^{bru} = ultimate bearing strength in the test direction specified by the subscript

F_x^{bro} (e %) = offset bearing strength (at e % bearing strain offset) in the test direction specified by the subscript

g = distance, perpendicular to force, from hole edge to shortest edge of specimen

h = specimen thickness

k = calculation factor used in bearing equations to distinguish single-fastener tests from double-fastener tests

K = calculation factor used in bearing equations to distinguish hole deformation in one member of the assembly from hole deformation shared between two members of the assembly in a strain equation

L_g = extensometer gage length

n = number of specimens per sample population

P = force carried by test specimen

P^f = force carried by test specimen at failure

P^{max} = maximum force carried by test specimen prior to failure

s_{n-1} = standard deviation statistic of a sample population for a given property

w = specimen width

x_i = test result for an individual specimen from the sample population for a given property

\bar{x} = mean or average (estimate of mean) of a sample population for a given property

δ = extensional displacement

ϵ = general symbol for strain, whether normal strain or shear strain

ϵ^{br} = bearing strain

σ^{br} = bearing stress

4. Summary of Test Method

4.1 Procedure A, Double Shear, Tension:

4.1.1 A flat, constant rectangular cross-section test specimen with a centerline hole located near the end of the specimen, as shown in the test specimen drawings of Figs. 1 and 2, is loaded at the hole in bearing. The bearing force is normally applied through a close-tolerance, lightly torqued fastener (or pin) that is reacted in double shear by a fixture similar to that shown in Figs. 3 and 4. The bearing force is created by loading the assembly in tension in a testing machine.

4.1.2 Both the applied force and the associated deformation of the hole are monitored. The hole deformation is normalized by the hole diameter to create an effective bearing strain. Likewise, the applied force is normalized by the projected hole area to create an effective bearing stress. The specimen is loaded until a maximum force has clearly been reached, whereupon the test is terminated so as to prevent masking of the true failure mode by large-scale hole distortion, in order to provide a more representative failure mode assessment. Bearing stress versus bearing strain for the entire loading regime is

plotted, and failure mode noted. The ultimate bearing strength of the material is determined from the maximum force carried prior to test termination.

4.1.3 The standard test configuration for this procedure does not allow any variation of the major test parameters. However, the following variations in specimen and test fixture configuration are allowed, but can be considered as being in accordance with this test method only as long as the values of all variant test parameters are prominently documented with the results:

Parameter	Standard	Variation
Loading condition:	double-shear	none
Mating material:	steel fixture	none
Number of holes:	1	none
Countersink:	none	none
Fit:	tight	any, if documented
Fastener torque:	2.2-3.4 N·m [20-30 lbf-in.]	any, if documented
Laminate:	quasi-isotropic	any, if documented
Fastener diameter:	6 mm [0.250 in.]	any, if documented
Edge distance ratio:	3	any, if documented
w/D ratio:	6	any, if documented
D/h ratio:	1.2-2	any, if documented

4.2 Procedure B, Single Shear, Two-Piece Specimen:

4.2.1 The flat, constant rectangular cross-section test specimen is composed of two like halves fastened together through one or two centerline holes located near one end of each half, as shown in the test specimen drawings of Figs. 5-8. The eccentricity in applied force that would otherwise result is minimized by a doubler bonded to, or frictionally retained against each grip end of the specimen, resulting in a force line-of-action along the interface between the specimen halves, through the centerline of the hole(s).

4.2.1.1 *Unstabilized Configuration (No Support Fixture)*—The ends of the test specimen are gripped in the jaws of a test machine and loaded in tension.

4.2.1.2 *Stabilized Configuration (Using Support Fixture)*—The test specimen is face-supported in a multi-piece bolted support fixture, similar to that shown in Fig. 9. The test specimen/fixture assembly is clamped in hydraulic wedge grips and the force is sheared into the support fixture and then sheared into the specimen. The stabilized configuration is primarily intended for compressive loading, although the specimen/fixture assembly may be loaded in either tension or compression.

4.2.2 Both the applied force and the associated deformation of the hole(s) are monitored. The deformation of the hole(s) is normalized by the hole diameter (a factor of two used to adjust for hole deformation occurring in the two halves) to result in an effective bearing strain. Likewise, the applied force is normalized by the projected hole area to yield an effective bearing stress. The specimen is loaded until a maximum force has clearly been reached, whereupon the test is terminated so as to prevent masking of the true failure mode by large-scale hole distortion, in order to provide a more representative failure mode assessment. Bearing stress versus bearing strain for the entire loading regime is plotted, and failure mode noted. The ultimate bearing strength of the material is determined from the maximum force carried prior to test termination.

DRAWING NOTES:

1. INTERPRET DRAWING IN ACCORDANCE WITH ANSI Y14.5M-1982, SUBJECT TO THE FOLLOWING:
2. ALL DIMENSIONS IN MILLIMETRES WITH DECIMAL TOLERANCES AS FOLLOWS:

NO DECIMAL	.X	.XX
±1	±0.3	±0.1
3. ALL ANGLES HAVE TOLERANCE OF ± .5°.
4. PLY ORIENTATION DIRECTION TOLERANCE RELATIVE TO [-A-] IS RECOMMENDED TO BE WITHIN ± .5°. (See Section 6.1.)
5. FINISH ON MACHINED EDGES NOT TO EXCEED 1.6√ (SYMBOLY IN ACCORDANCE WITH ASA B46.1, WITH ROUGHNESS HEIGHT IN MICROMETRES.)
6. VALUES TO BE PROVIDED FOR THE FOLLOWING, SUBJECT TO ANY RANGES SHOWN ON THE FIELD OF DRAWING: MATERIAL, LAY-UP, PLY ORIENTATION REFERENCE RELATIVE TO [-A-], OVERALL LENGTH, HOLE DIAMETER, AND COUPON THICKNESS FOR PROCEDURE D, REDUCE LENGTH, L, AS REQUIRED IN ORDER TO PREVENT BUCKLING

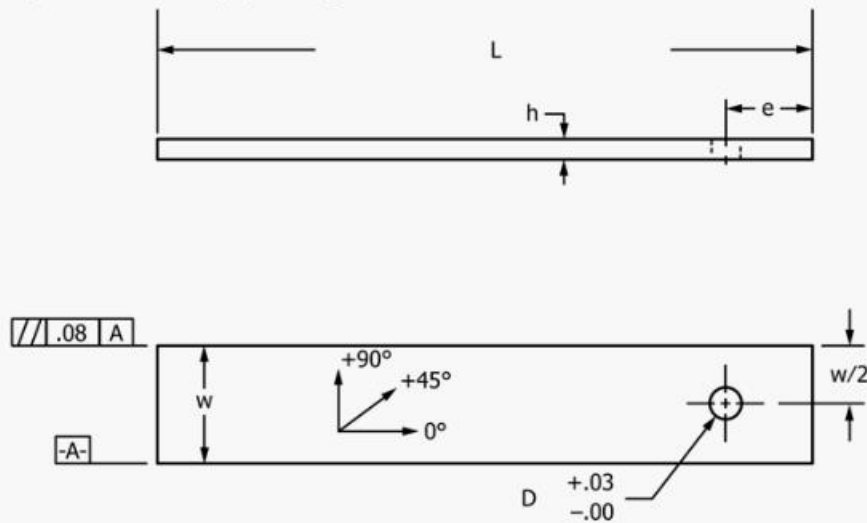

Parameter	Standard Dimension, mm
fastener or pin diameter, d	6 + 0.00/-0.03
hole diameter, D	6 + 0.03/-0.00
thickness range, h	3-5
length, L	135
width, w	36 ± 1
edge distance, e	18 ± 1
countersink	none

FIG. 1 Double-Shear and Single-Shear One-Piece Test Specimen Drawing (SI)

4.2.3 The standard test configuration for this procedure does not allow any variation of the major test parameters. However, the following variations in specimen and test fixture configuration are allowed, but can be considered as being in accordance with this test method only as long as the values of all variant test parameters are prominently documented with the results:

Parameter	Standard	Variation
Loading condition:	single-shear	none
Support fixture:	no	yes, if documented
Number of holes:	1	1 or 2
Countersunk holes:	no	yes, if documented
Grommets:	no	yes, if documented
Mating material:	same laminate	any, if documented
Fit:	tight	any, if documented
Fastener torque:	2.2-3.4 N-m [20-30 lbf-in.]	any, if documented
Laminate:	quasi-isotropic	any, if documented
Fastener diameter:	6 mm [0.250 in.]	any, if documented
Edge distance ratio:	3	any, if documented
w/D ratio:	6	any, if documented
D/h ratio:	1.2-2	any, if documented

4.3 Procedure C, Single Shear, One-Piece Specimen:

4.3.1 A flat, constant rectangular cross-section test specimen with a centerline hole located near the end of the specimen, as shown in the test specimen drawings of Figs. 1 and 2, is loaded at the hole in bearing. The bearing force is normally applied, by a fixture similar to that shown in Fig. 10, through a close-tolerance, lightly torqued fastener that is reacted in single shear, as shown in Fig. 11. The bearing force is created by loading the assembly in tension in a testing machine.

4.3.2 Both the applied force and the associated deformation of the hole are monitored. The hole deformation is normalized by the hole diameter to create an effective bearing strain. Likewise, the applied force is normalized by the projected hole area to create an effective bearing stress. The specimen is loaded until a maximum force has clearly been reached, whereupon the test is terminated so as to prevent masking of the true failure mode by large-scale hole distortion, in order to provide a more representative failure mode assessment. Bearing stress versus bearing strain for the entire loading regime is plotted, and failure mode noted. The ultimate bearing strength

DRAWING NOTES:

1. INTERPRET DRAWING IN ACCORDANCE WITH ANSI Y14.5M-1982, SUBJECT TO THE FOLLOWING:
2. ALL DIMENSIONS IN INCHES WITH DECIMAL TOLERANCES AS FOLLOWS:

.X	.XX	.XXX
± .1	± .03	± .01
3. ALL ANGLES HAVE TOLERANCE OF ± .5°.
4. PLY ORIENTATION DIRECTION TOLERANCE RELATIVE TO \square -A- IS RECOMMENDED TO BE WITHIN ± .5°. (See Section 6.1.)
5. FINISH ON MACHINED EDGES NOT TO EXCEED 64√ (SYMBOLY IN ACCORDANCE WITH ASA B46.1, WITH ROUGHNESS HEIGHT IN MICROINCHES.)
6. VALUES TO BE PROVIDED FOR THE FOLLOWING, SUBJECT TO ANY RANGES SHOWN ON THE FIELD OF DRAWING: MATERIAL, LAY-UP, PLY ORIENTATION REFERENCE RELATIVE TO \square -A-, OVERALL LENGTH, HOLE DIAMETER, AND COUPON THICKNESS.
7. FOR PROCEDURE D, REDUCE LENGTH, L, AS REQUIRED IN ORDER TO PREVENT BUCKLING

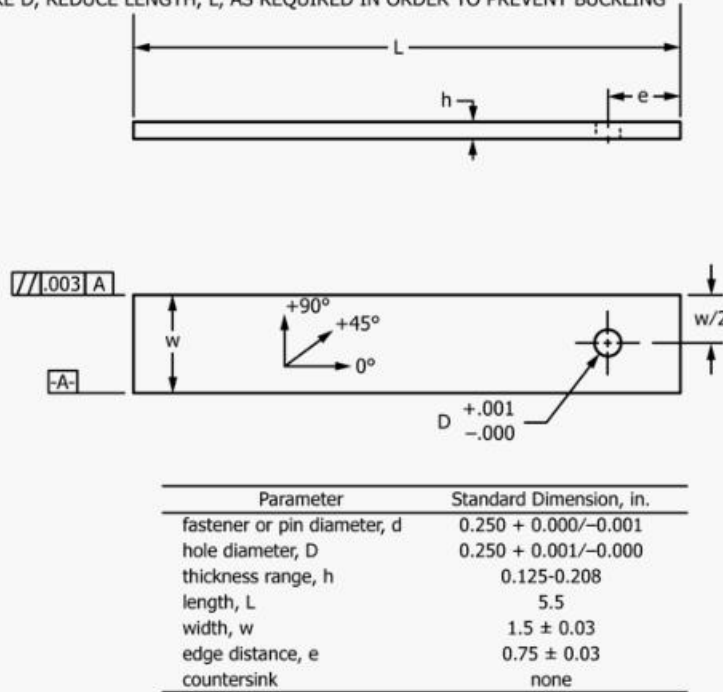

FIG. 2 Double-Shear and One-Piece Single-Shear Test Specimen Drawing (Inch-Pound)

of the material is determined from the maximum force carried prior to test termination.

4.3.3 The standard test configuration for this procedure does not allow any variation of the major test parameters. However, the following variations in specimen and test fixture configuration are allowed, but can be considered as being in accordance with this test method only as long as the values of all variant test parameters are prominently documented with the results:

Parameter	Standard	Variation
Loading condition:	single-shear	none
Mating material:	steel fixture	none
Number of holes:	1	none
Countersink:	yes	no, if documented
Fit:	tight	any, if documented
Fastener torque:	2.2-3.4 N·m [20-30 lbf·in.]	any, if documented
Laminate:	quasi-isotropic	any, if documented
Fastener diameter:	6 mm [0.250 in.]	any, if documented
Edge distance ratio:	3	any, if documented
w/D ratio:	6	any, if documented
D/h ratio:	1.2-2	any, if documented

4.4 Procedure D, Double Shear, Compression:

4.4.1 A flat, constant rectangular cross-section test specimen with a centerline hole located near the end of the specimen, as shown in the test specimen drawings of Figs. 1 and 2, is loaded at the hole in bearing. The bearing force is normally applied, by a fixture similar to that shown in Fig. 12, through a close-

tolerance, lightly torqued fastener (or pin) that is reacted in double shear, as shown in Fig. 13. The bearing force is created by loading the assembly in compression in a testing machine.

4.4.2 Both the applied force and the associated deformation of the hole are monitored. The hole deformation is normalized by the hole diameter to create an effective bearing strain. Likewise, the applied force is normalized by the projected hole area to create an effective bearing stress. The specimen is loaded until a maximum force has clearly been reached, whereupon the test is terminated so as to prevent masking of the true failure mode by large-scale hole distortion, in order to provide a more representative failure mode assessment. Bearing stress versus bearing strain for the entire loading regime is plotted, and failure mode noted. The ultimate bearing strength of the material is determined from the maximum force carried prior to test termination.

4.4.3 The standard test configuration for this procedure does not allow any variation of the major test parameters, other than overall specimen length (in order to preclude specimen buckling). However, the following variations in specimen and test fixture configuration are allowed, but can be considered as being in accordance with this test method only as long as the values of all variant test parameters are prominently documented with the results:

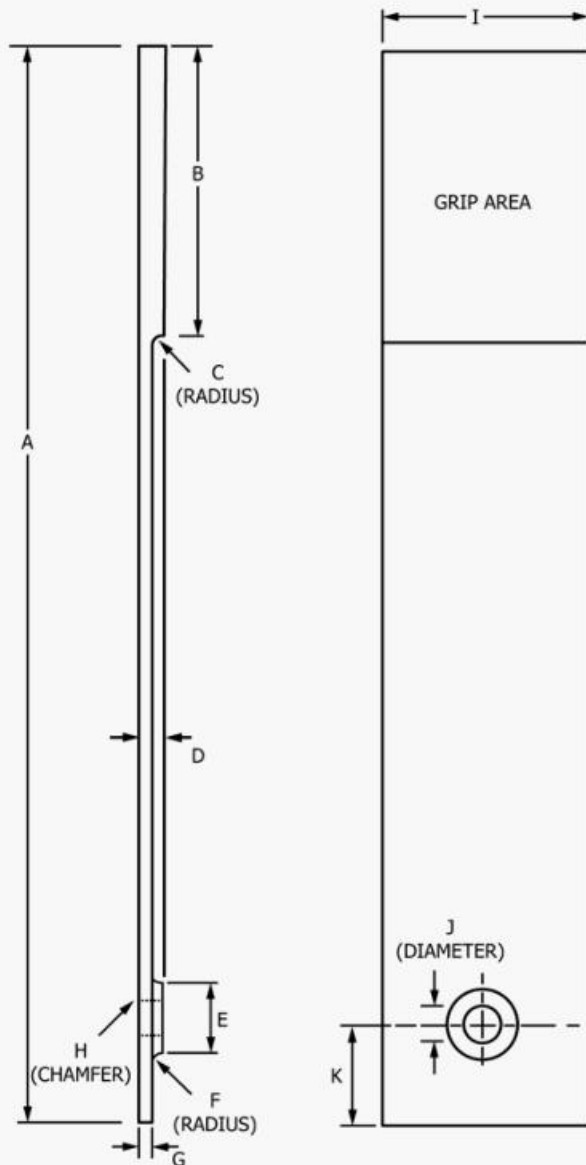

Recommended Material: 17-4PH Stainless Steel, 1 GPa [145 ksi] yield													L	M	N	P
mm	A	B	C	D	E	F	G	H	I	J	K	0.3	0.1	0.013	0.8	
inch	7.75	2.00	0.06	0.20	0.50	0.06	0.12	0.04	1.50	0.25	0.75	0.03	0.01	0.003	32	
															micro-in	
															micro-in	

NOTES:

1. Tolerances unless otherwise stated are (SI: X.X±L, X.XX±M) (US: X.XX±L, X.XXX±M)
2. Surface finish is P.

FIG. 3 Fixture Loading Plate for Procedure A (2 Required)

Parameter	Standard	Variation
Loading condition:	double-shear	none
Mating material:	steel fixture	none
Number of holes:	1	none
Countersink:	none	none
Fit:	tight	any, if documented
Fastener torque:	2.2-3.4 N-m [20-30 lbf-in.]	any, if documented
Laminate:	quasi-isotropic	any, if documented
Fastener diameter:	6 mm [0.250 in.]	any, if documented
Edge distance ratio:	3	any, if documented
w/D ratio:	6	any, if documented
D/h ratio:	1.2-2	any, if documented

5. Significance and Use

5.1 This test method is designed to produce bearing response data for material specifications, research and development, quality assurance, and structural design and analysis. The standard configuration for each procedure is very specific and is intended primarily for development of quantitative double- and single-shear bearing response data for material comparison and structural design. Procedures A and D, the double-shear configurations, with a single fastener

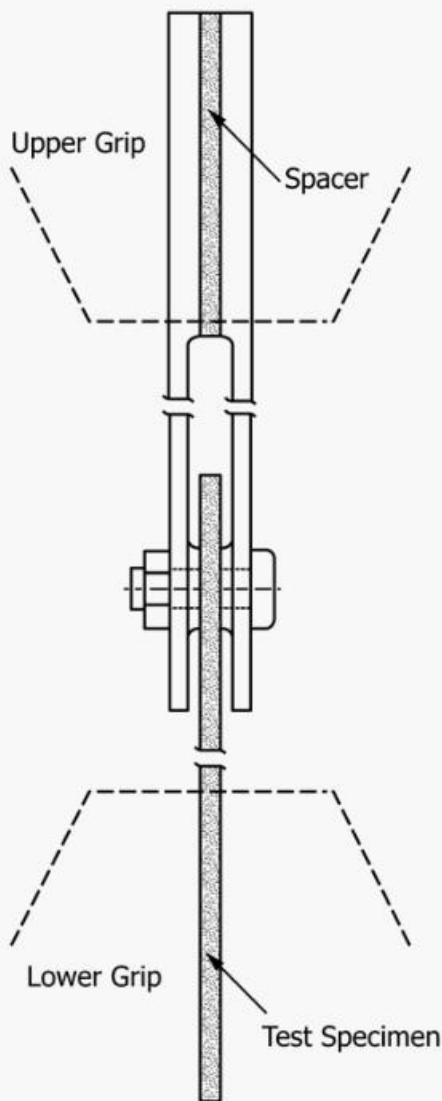

FIG. 4 Fixture Assembly for Procedure A

loaded in shear and reacted by laminate tension or compression, are particularly recommended for basic material evaluation and comparison. Procedures B and C, the single-shear, single- or double-fastener configurations are more useful in evaluation of specific joint configurations, including fastener failure modes. The Procedure B specimen may be tested in either an unstabilized (no support fixture) or stabilized configuration. The unstabilized configuration is intended for tensile loading and the stabilized configuration is intended for compressive loading (although tensile loading is permitted). The Procedure C specimen is particularly well-suited for development of countersunk-fastener bearing strength data where a near-double-shear fastener rotational stiffness is desired. These Procedure B and C configurations have been extensively used in the development of design allowables data.

5.2 It is important to note that these four procedures, using the standard test configurations, will generally result in bearing strength mean values that are not of the same statistical population, and thus not in any way a “basic material property.”

NOTE 2—Typically, Procedure D will yield slightly higher strengths than Procedure A (due to the finite edge distance, e , in Procedure A); while

Procedure C will yield significantly higher strengths than Procedure B (due to the larger fastener rotation and higher peak bearing stress in Procedure B). For protruding head fasteners, Procedure D will typically yield somewhat higher results than Procedure C (due to both stress peaking and finite edge distance in Procedure C), and Procedures A and C yield roughly equivalent results.

5.3 It is also important to note that the parameter variations of the four procedures (tabulated in Section 4) provide flexibility in the conduct of the test, allowing adaptation of the test setup to a specific application. However, the flexibility of test parameters allowed by these variations makes meaningful comparison between datasets difficult if the datasets were not tested using the same procedure and identical test parameters.

5.4 General factors that influence the mechanical response of composite laminates and should therefore be reported include the following: material, methods of material preparation and lay-up, specimen stacking sequence, specimen preparation, specimen conditioning, environment of testing, specimen alignment and gripping, speed of testing, time at temperature, void content, and volume percent reinforcement.

5.5 Specific factors that influence the bearing response of composite laminates and should therefore be reported include not only the loading method (either Procedure A, B, or C) but the following: (for all procedures) edge distance ratio, width to diameter ratio, diameter to thickness ratio, fastener type, fastener shear strength, fastener torque, fastener or pin material, fastener or pin clearance, tensile or compressive loading, countersink angle and depth of countersink, type of grommet (if used), type of mating material, number of fasteners, and type of support fixture (if used). Properties, in the test direction, which may be obtained from this test method include the following:

5.5.1 Ultimate bearing strength, F^{bru} , of the composite laminate or laminate-fastener joint, or both;

5.5.2 Offset bearing strength, F^{bro} , of the composite laminate or laminate-fastener joint, or both; and

5.5.3 Bearing stress/bearing strain curve.

6. Interferences

6.1 *Type of Loading*—Results from Procedures A–D should not generally be expected to yield comparable bearing strength or failure mode results. Also, Procedure B results will likely vary depending on whether a one- or two-fastener specimen is used, and whether the loading direction is tension or compression; due to differences in load path, localized damage modes, and support fixture friction.

6.2 *Material and Specimen Preparation*—Bearing response is sensitive to poor material fabrication practices (including lack of control of fiber alignment), damage induced by improper specimen machining (hole preparation is especially critical), and torqued fastener installation. Fiber alignment relative to the specimen coordinate axis should be maintained as carefully as possible, although there is currently no standard procedure to ensure or determine this alignment. A practice that has been found satisfactory for many materials is the addition of small amounts of tracer yarn to the prepreg parallel to the 0° direction, added either as part of the prepreg production or as

DRAWING NOTES:

1. INTERPRET DRAWING IN ACCORDANCE WITH ANSI Y14.5M-1982, SUBJECT TO THE FOLLOWING:
2. ALL DIMENSIONS IN MILLIMETRES WITH DECIMAL TOLERANCES AS FOLLOWS:

NO DECIMAL	.X	.XX
±1	±0.3	±0.1
3. ALL ANGLES HAVE TOLERANCE OF +/- .5°.
4. PLY ORIENTATION DIRECTION TOLERANCE RELATIVE TO -A- WITHIN +/- .5°.
5. FINISH ON MACHINED EDGES NOT TO EXCEED $\sqrt{1.6}$ SYMBOLOGY IN ACCORDANCE WITH ASA B46.1, WITH ROUGHNESS HEIGHT IN MICROMETRES.)
6. VALUES TO BE PROVIDED FOR THE FOLLOWING, SUBJECT TO ANY RANGES SHOWN ON THE FIELD OF DRAWING; MATERIAL, LAY-UP, PLY ORIENTATION REFERENCE RELATIVE TO -A-, OVERALL LENGTH, HOLE DIAMETER, COUNTERSINK DETAILS, COUPON THICKNESS, DOUBLER MATERIAL, DOUBLER ADHESIVE.

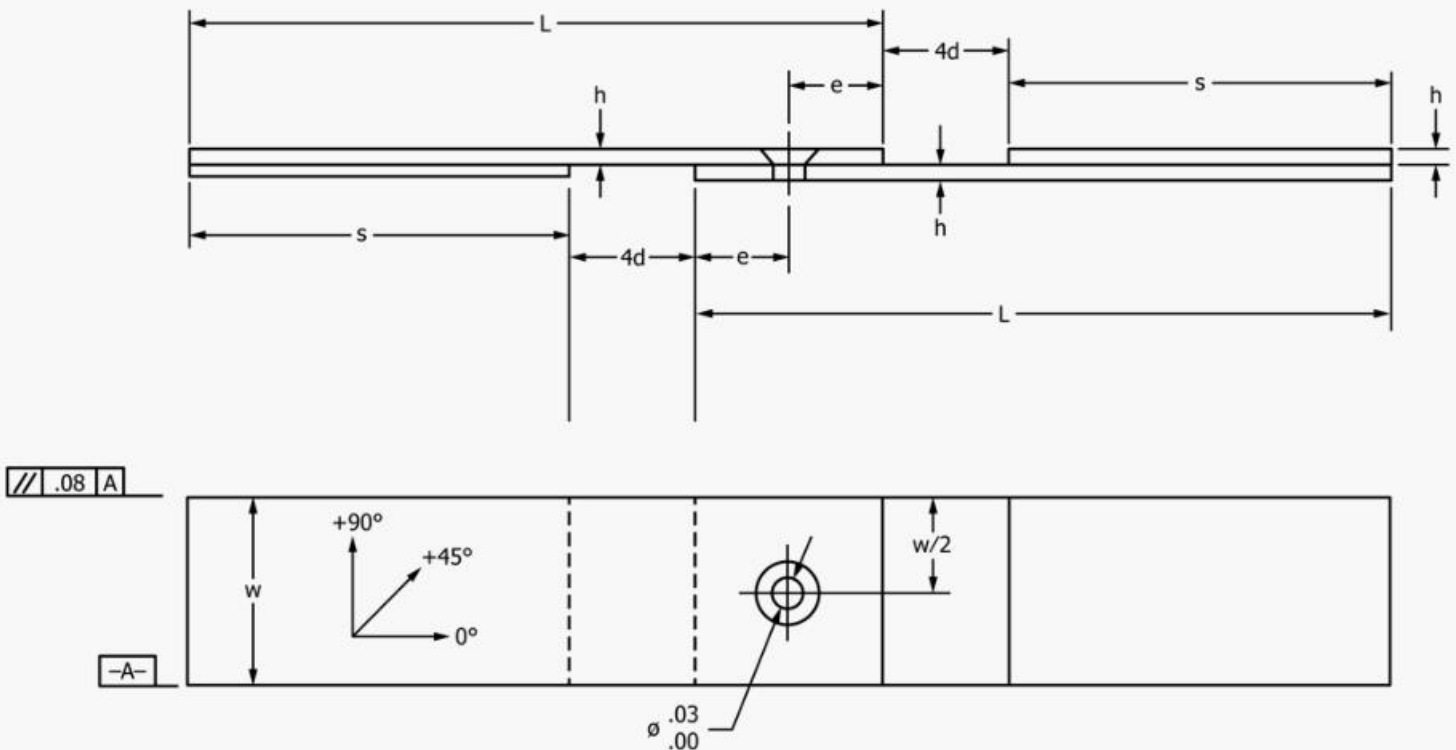

Parameters	Standard Dimensions of Specimen (mm)	
	without support fixture	with support fixture
fastener diameter, d	6+0.00/-0.03	6+0.00/-0.03
hole diameter, ϕ	6+0.03/-0.00	6+0.03/-0.00
thickness range, h	3-5	3-5
length, L	135	189
width, w	36 +/- 1	36 +/- 1
edge distance, e	18 +/- 1	18 +/- 1
countersink	none(optional)	none (optional)
doubler length, s	75	129

FIG. 5 Single-Shear, Two-Piece Single-Fastener Test Specimen Drawing (SI)

part of panel fabrication. See Guide [D5687/D5687M](#) for further information on recommended specimen preparation practices.

6.3 *Restraining Surfaces*—The degree to which out-of-plane hole deformation is possible, due to lack of restraint by the fixture or the fastener, has been shown to affect test results.

DRAWING NOTES:

1. INTERPRET DRAWING IN ACCORDANCE WITH ANSI Y14.5M-1982, SUBJECT TO THE FOLLOWING:
2. ALL DIMENSIONS IN INCHES WITH DECIMAL TOLERANCES AS FOLLOWS:

.X	.XX	.XXX
+/- .1	+/- .03	+/- .003
3. ALL ANGLES HAVE TOLERANCE OF +/- .5°.
4. PLY ORIENTATION DIRECTION TOLERANCE RELATIVE TO [-A-] WITHIN +/- .5°.
5. FINISH ON MACHINED EDGES NOT TO EXCEED $\sqrt{64}$ (SYMBOLY IN ACCORDANCE WITH ASA B46.1, WITH ROUGHNESS HEIGHT IN MICROINCHES.)
6. VALUES TO BE PROVIDED FOR THE FOLLOWING, SUBJECT TO ANY RANGES SHOWN ON THE FIELD OF DRAWING; MATERIAL, LAY-UP, PLY ORIENTATION REFERENCE RELATIVE TO [-A-], OVERALL LENGTH, HOLE DIAMETER, COUNTERSINK DETAILS, COUPON THICKNESS, DOUBLER MATERIAL, DOUBLER ADHESIVE.

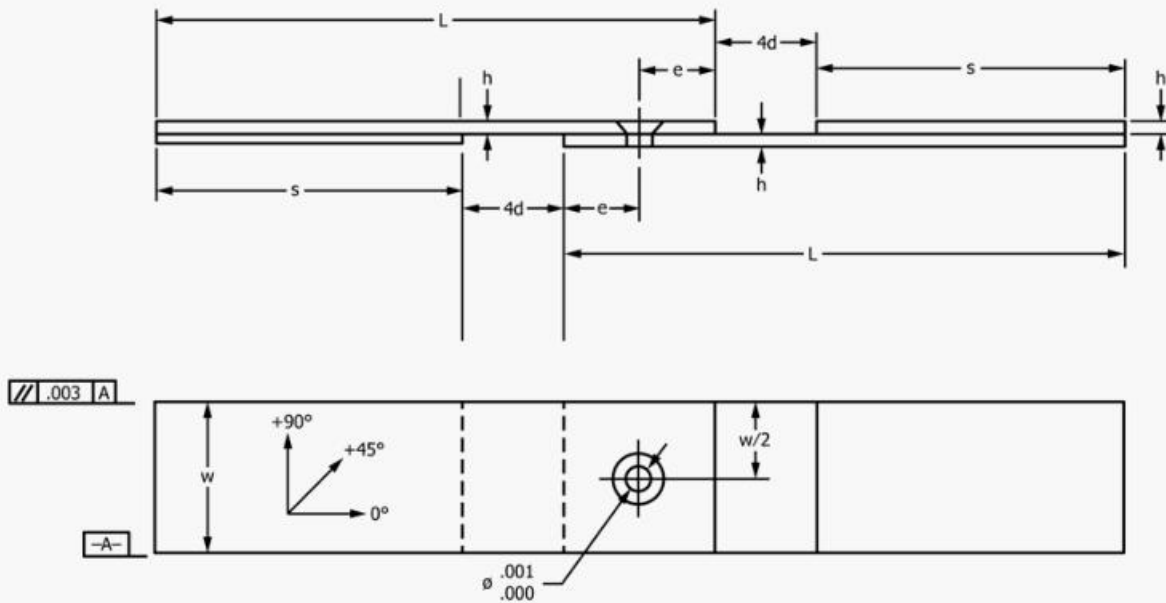

Parameters	Standard Dimensions of Specimen (inches)	
	without support fixture	with support fixture
fastener diameter, d	0.250 + 0.000/-0.001	0.250 + 0.000/-0.001
hole diameter, ϕ	0.250 + 0.001/-0.000	0.250 + 0.001/-0.000
thickness range, h	0.125 - 0.208	0.125 - 0.208
length, L	5.5	7.5
width, w	1.5 +/- 0.03	1.5 +/- 0.03
edge distance, e	0.75 +/- 0.03	0.75 +/- 0.03
countersink	none(optional)	none (optional)
doubler length, s	3.0	5.0

FIG. 6 Single-Shear Two-Piece Test Specimen Drawing (Inch-Pound)

6.4 *Cleanliness*—The degree of cleanliness of the mating surfaces has been found to produce significant variations in test results.

6.5 *Eccentricity (Procedure B only)*—A loading eccentricity is created in single-shear tests by the offset, in one plane, of the line of action of force between each half of the test specimen. This eccentricity creates a moment that, particularly in clearance-hole tests, rotates the fastener, resulting in an uneven contact stress distribution through the thickness of the specimen. The effect of this eccentricity upon test results is strongly dependent upon the degree of clearance in the hole, fastener diameter-to-specimen-thickness ratio, fastener torque, the size of the fastener head, the mating area, the coefficient of friction between the specimen and the mating material, the thickness and stiffness of the specimen, the thickness and stiffness of the

mating material, and the configuration of the support fixture. Consequently, results obtained from this procedure where the support fixture is used may not accurately replicate behavior in other structural configurations.

6.6 *Eccentricity (Procedure C only)*—Loading eccentricity is less of a factor in Procedure C, due to the test fixture rigidity. However, this combination of loading eccentricity and fixture rigidity creates a combined bending moment and shear on the fastener that can lead to fastener yielding prior to composite material bearing failure.

6.7 *Hole Preparation*—Due to the dominating presence of the filled hole(s), results from this test method are relatively insensitive to parameters that would be of concern in an unnotched tensile or compressive property test. However, since

- DRAWING NOTES:
1. INTERPRET DRAWING IN ACCORDANCE WITH ANSI Y14.5M-1982, SUBJECT TO THE FOLLOWING:
 2. ALL DIMENSIONS IN MM WITH DECIMAL TOLERANCES AS FOLLOWS:
 NO DECIMAL .X .XX X
 ± 1 ± 0.3 ± 0.1
 3. ALL ANGLES HAVE TOLERANCE OF $\pm 0.5^\circ$.
 4. PLY ORIENTATION DIRECTION TOLERANCE RELATIVE TO \square -A-
 WITHIN $\pm 0.5^\circ$.
 5. FINISH ON MACHINED EDGES NOT TO EXCEED $\sqrt{1.6}$
 SYMBOLY IN ACCORDANCE WITH ASA B46.1, WITH ROUGHNESS
 HEIGHT IN MICROMETRES.)
 6. VALUES TO BE PROVIDED FOR THE FOLLOWING, SUBJECT TO ANY RANGES
 SHOWN ON THE FIELD OF DRAWING; MATERIAL, LAY-UP, PLY ORIENTATION
 REFERENCE RELATIVE TO \square -A-, OVERALL LENGTH, HOLE DIAMETER, COUNTERSINK DETAILS,
 COUPON THICKNESS, DOUBLER MATERIAL, DOUBLER ADHESIVE.

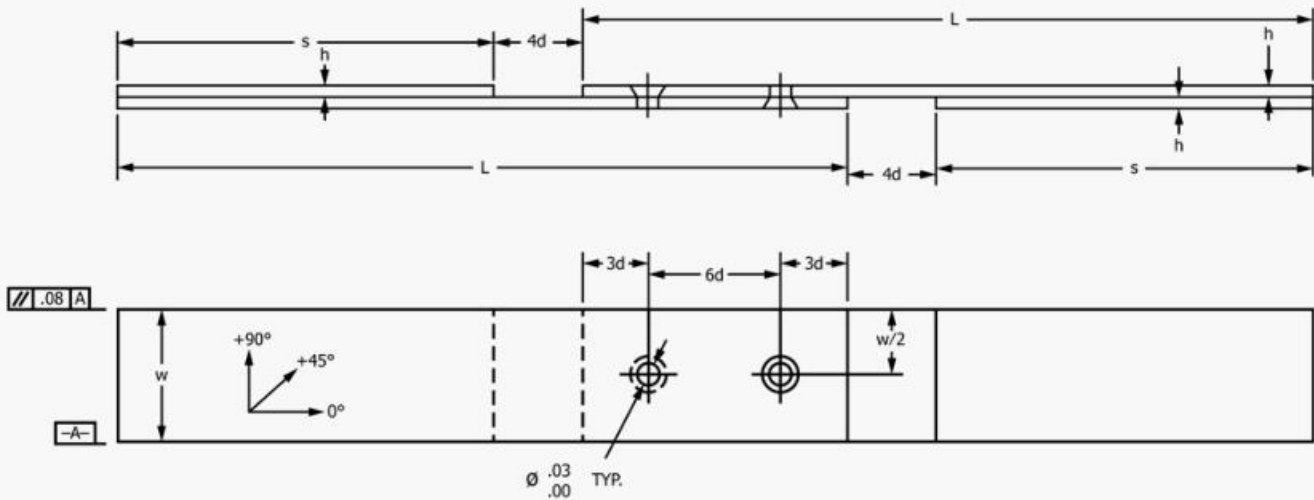

Parameters	Standard Dimensions of Specimen (mm)	
	without support fixture	with support fixture
fastener diameter, d	6 + 0.00/-0.03	6 + 0.00/-0.03
hole diameter, \emptyset	6 + 0.03/-0.00	6 + 0.03/-0.00
thickness range, h	3-5	3-5
length, L	210	210
width, w	36 +/- 1	36 +/- 1
edge distance, e	18 +/- 1	18 +/- 1
countersink	none(optional)	none (optional)
doubler length, s	108	108

FIG. 7 Single-Shear, Two-Piece Double-Fastener Test Specimen Drawing (SI)

the filled hole(s) dominates the strength, consistent preparation of the hole(s) without damage to the laminate is important to meaningful results. Damage due to hole preparation will affect strength results and can reduce the calculated strength.

6.8 *Fastener-Hole Clearance*—Results are affected by the clearance arising from the difference between hole and fastener diameters. Clearance can change the observed specimen behavior by delaying the onset of bearing damage. Damage due to insufficient clearance during fastener installation will affect strength results. Countersink flushness (depth or protrusion of the fastener head in a countersunk hole) will affect strength results and may affect the observed failure mode. For these reasons, both the hole and fastener diameters must be accurately measured and recorded. A typical aerospace tolerance on fastener-hole clearance is $+75/-0 \mu\text{m}$ [$+0.003/-0.000 \text{ in.}$] for structural fastener holes.

6.9 *Fastener Torque/Pre-load*—Results are affected by the installed fastener pre-load (clamping pressure). Laminates can exhibit significant differences in both maximum force at failure

and failure mode due to changes in fastener pre-load under bearing loading. The critical pre-load condition (that is, either high or low clamping pressure) can vary depending upon the type of loading, the laminate stacking sequence and the desired failure mode. The nominal test configuration uses a relatively low level of fastener installation torque to give conservative bearing stress results. For specimens that produce bearing failure modes, bearing strengths for specimens with high clamping pressure fasteners are almost always higher than the corresponding low clamping pressure bearing strengths. Valid bearing strength results should only be reported when appropriate failure modes are observed, in accordance with 11.5.

6.10 *Fastener Strength/Modulus*—Results are affected by any permanent deformation of fasteners. Fastener yield failure is not an acceptable failure mode. Fastener manufacturers typically report static shear ultimate specification-minimum strengths for their products. Thus, knowledge of mean-to-minimum ultimate strength ratio, fastener alloy, and shear ultimate-to-yield ratio are generally required to accurately

DRAWING NOTES:

1. INTERPRET DRAWING IN ACCORDANCE WITH ANSI Y14.5M-1982, SUBJECT TO THE FOLLOWING:
2. ALL DIMENSIONS IN INCHES WITH DECIMAL TOLERANCES AS FOLLOWS:

.X	.XX	.XXX
+/- .1	+/- .03	+/- .003
3. ALL ANGLES HAVE TOLERANCE OF +/- .5°.
4. PLY ORIENTATION DIRECTION TOLERANCE RELATIVE TO -A- WITHIN +/- .5°.
5. FINISH ON MACHINED EDGES NOT TO EXCEED $\sqrt{64}$ SYMBOLY IN ACCORDANCE WITH ASA B46.1, WITH ROUGHNESS HEIGHT IN MICROINCHES.)
6. VALUES TO BE PROVIDED FOR THE FOLLOWING, SUBJECT TO ANY RANGES SHOWN ON THE FIELD OF DRAWING; MATERIAL, LAY-UP, PLY ORIENTATION REFERENCE RELATIVE TO -A-, OVERALL LENGTH, HOLE DIAMETER, COUNTERSINK DETAILS, COUPON THICKNESS, DOUBLER MATERIAL, DOUBLER ADHESIVE.

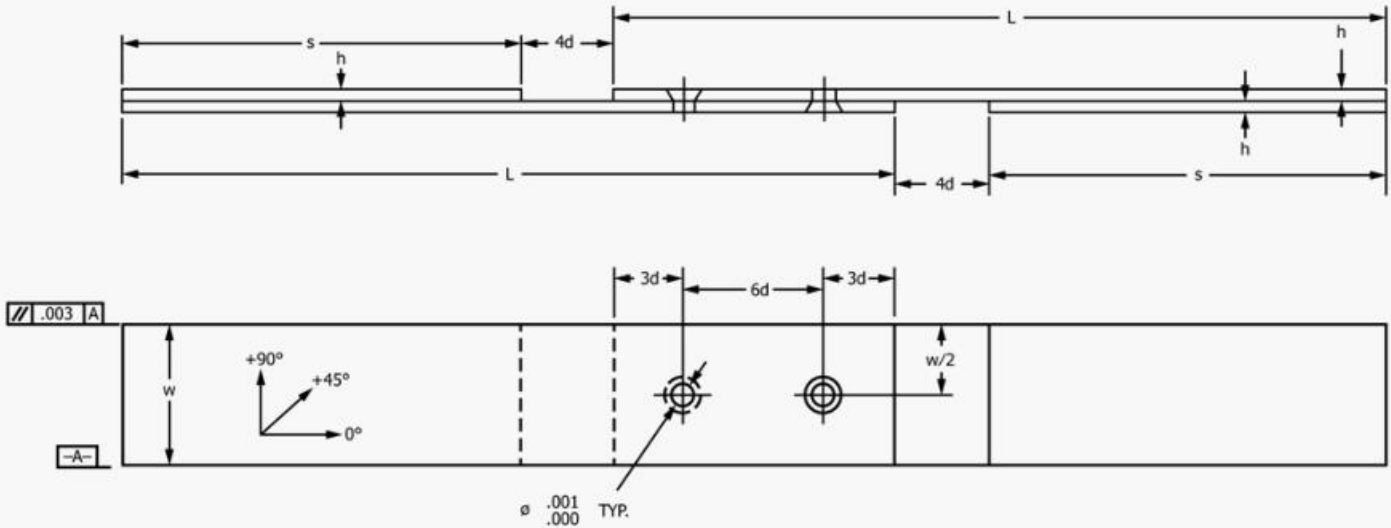

Parameters	Standard Dimensions of Specimen (inches)	
	without support fixture	with support fixture
fastener diameter, d	0.250 + 0.000/-0.001	0.250 + 0.000/-0.001
hole diameter, ø	0.250 + 0.001/-0.000	0.250 + 0.001/-0.000
thickness range, h	0.125-0.208	0.125-0.208
length, L	8.25	8.25
width, w	1.5 +/- 0.03	1.5 +/- 0.03
edge distance, e	0.75 +/- 0.03	0.75 +/- 0.03
countersink	none(optional)	none (optional)
doubler length, s	4.25	4.25

FIG. 8 Single-Shear, Two-Piece Double Fastener Test Specimen Drawing (Inch-Pound)

predict fastener shear yield strength. Furthermore, single-shear bearing test configurations (Procedures B and C) impart significant bending stress to the fasteners, which is influenced by fastener modulus and h/d ratio and also must be taken into account in predicting the maximum applied force below which no bending- or shear-induced fastener yielding will occur. Valid bearing strength results should only be reported when appropriate failure modes are observed, in accordance with 11.5.

6.11 *Specimen Geometry*—Results are affected by the ratio of specimen width to hole diameter; this ratio should be maintained at 6, unless the experiment is investigating the influence of this ratio, or invalid (bypass) failure modes may occur. Results may also be affected by the ratio of hole diameter to thickness; the preferred ratio is the range from 1.5-3.0 unless the experiment is investigating the influence of this ratio. Results may also be affected by the ratio of

countersunk (flush) head depth to thickness (d_{csk}/h); the preferred ratio is the range from 0.0-0.7 unless the experiment is investigating the influence of this ratio. Results may also be affected by the ratio of ungripped specimen length to specimen width; this ratio should be maintained as shown, unless the experiment is investigating the influence of this ratio.

6.12 *Material Orthotropy*—The degree of laminate orthotropy strongly affects the failure mode and measured bearing strengths. Bearing strength results should only be reported when appropriate and valid failure modes are observed, in accordance with 11.5.

6.13 *Thickness Scaling*—Thick composite structures do not necessarily fail at the same strengths as thin structures with the same laminate orientation and geometric ratios (w/D, e/D, D/h, etc.). Thus, data gathered using these procedures may not translate directly into equivalent thick-structure properties.

METRIC HARDWARE
 NA0036–060029 BOLT (4)
 NA0179B–060 WASHER (8 +)
 (NO. AS REQUIRED)
 NA033–060M NUT (4)
 (OR EQUIVALENT)
 OR FOR THREADED PLATES
 NA0036–060027 BOLT (4)
 NA0179B–060 WASHER (4)
 (OR EQUIVALENT)

U.S. CUSTOMARY HARDWARE
 NAS6604–22 BOLT
 NAS1149D0463J WASHER (8+)
 (NO. AS REQUIRED)
 MS21042L4 NUT (4)
 (OR EQUIVALENT)
 OR FOR THREADED PLATES
 NAS6604–18 BOLT (4)
 NAS1149D0463J WASHER (4)
 (OR EQUIVALENT)

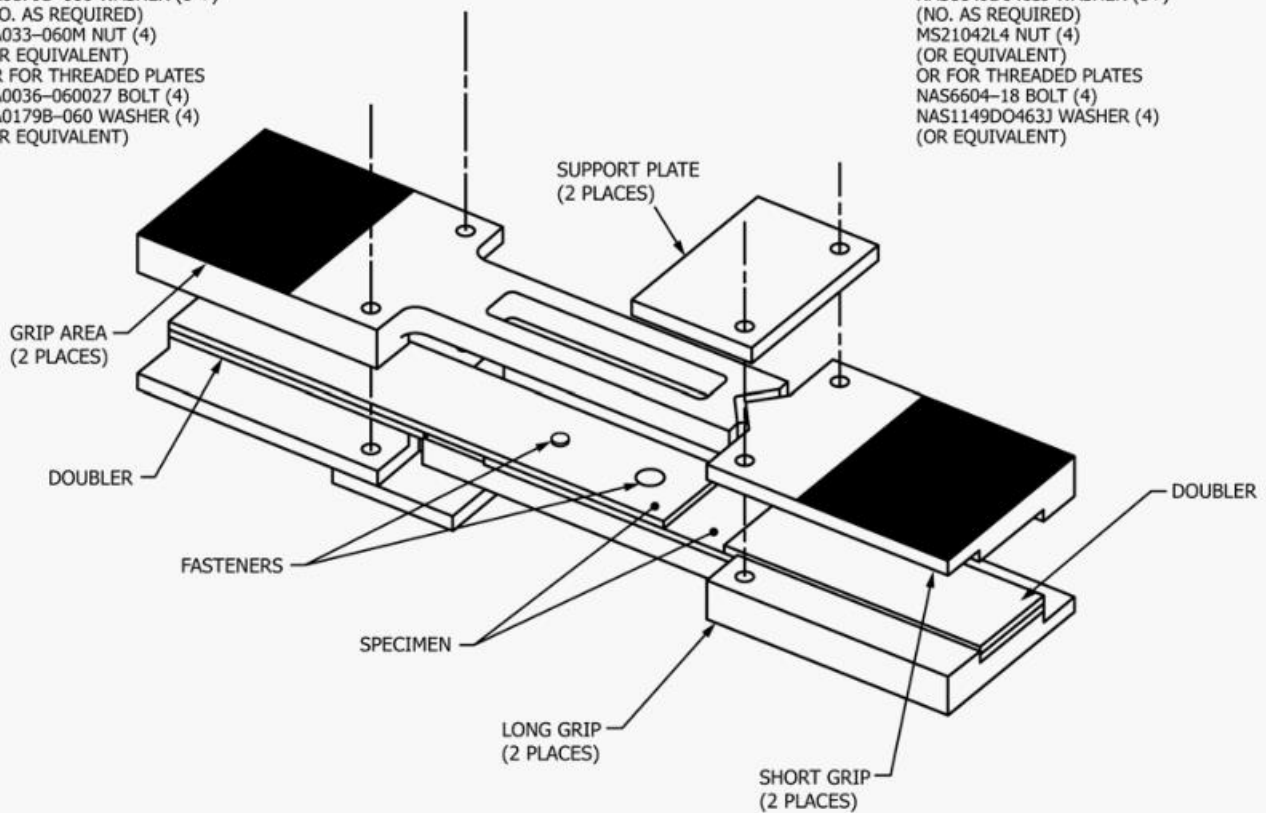

FIG. 9 Support Fixture Assembly for Procedure B

6.14 *Buckling (Procedure D only)*—Procedure D results may be affected by buckling of the unsupported specimen segment if this length is not minimized as directed in 8.2 and the Fig. 13 notes.

6.15 *Environment*—Results are affected by the environmental conditions under which the tests are conducted. Laminates tested in various environments can exhibit significant differences in both bearing strength and failure mode. Experience has demonstrated that elevated temperature and humid environments are generally critical for bearing failure modes. However, critical environments must be assessed independently for each material system, stacking sequence, and torque condition tested.

6.16 *Other*—Test Methods E238 and D953 contain further discussions of other variables affecting bearing-type testing.

7. Apparatus

7.1 *Micrometers*—The micrometer(s) shall use a 4 to 6-mm [0.16 to 0.25-in.] nominal diameter ball-interface on irregular surfaces such as the bag-side of a laminate, and a flat anvil interface on machined edges or very smooth tooled surfaces. The accuracy of the instrument(s) shall be suitable for reading to within 1 % of the sample width and thickness. For typical specimen geometries, an instrument with an accuracy of $\pm 2.5 \mu\text{m}$ [± 0.0001 in.] is desirable for thickness measurement, while an instrument with an accuracy of $\pm 25 \mu\text{m}$ [± 0.001 in.] is desirable for width measurement.

7.2 *Loading Fastener or Pin*—The fastener (or pin) type and, if applicable, nut type, shall be specified as initial test parameters and reported. Both fastener and nut shall be strong enough to preclude yielding at maximum applied force, unless fastener type is a test parameter (in which case expected fastener yield force shall be reported). The assembly torque (if applicable) shall be specified as an initial test parameter and reported. This value may be a measured torque or a specification torque for fasteners with lock-setting features. A measured torque, run-on torque and clamp-up torque shall be separately specified if run-on torque is expected to be more than 10 % of clamp-up torque. If washers are utilized, the washer type, number of washers, and washer location(s) shall be specified as initial test parameters and reported. The reuse of fasteners is not recommended due to potential differences in through-thickness clamp-up for a given torque level, caused by wear of the threads. If fasteners are reused, this shall be noted and reported.

7.3 Overall Test Fixture and Instrumentation Assembly:

7.3.1 *Procedure A*—The force shall be applied to the specimen by means of a double-shear clevis similar to that shown in Figs. 3 and 4, using a single loading fastener or pin. For torqued tests, the clevis shall allow a torqued fastener to apply a transverse compressive force to the specimen only around the periphery of the hole, to an extent of 2D (twice the hole diameter). While flat loading plates may be used in lieu of the bossed configuration shown in Figs. 3 and 4, both the 2D

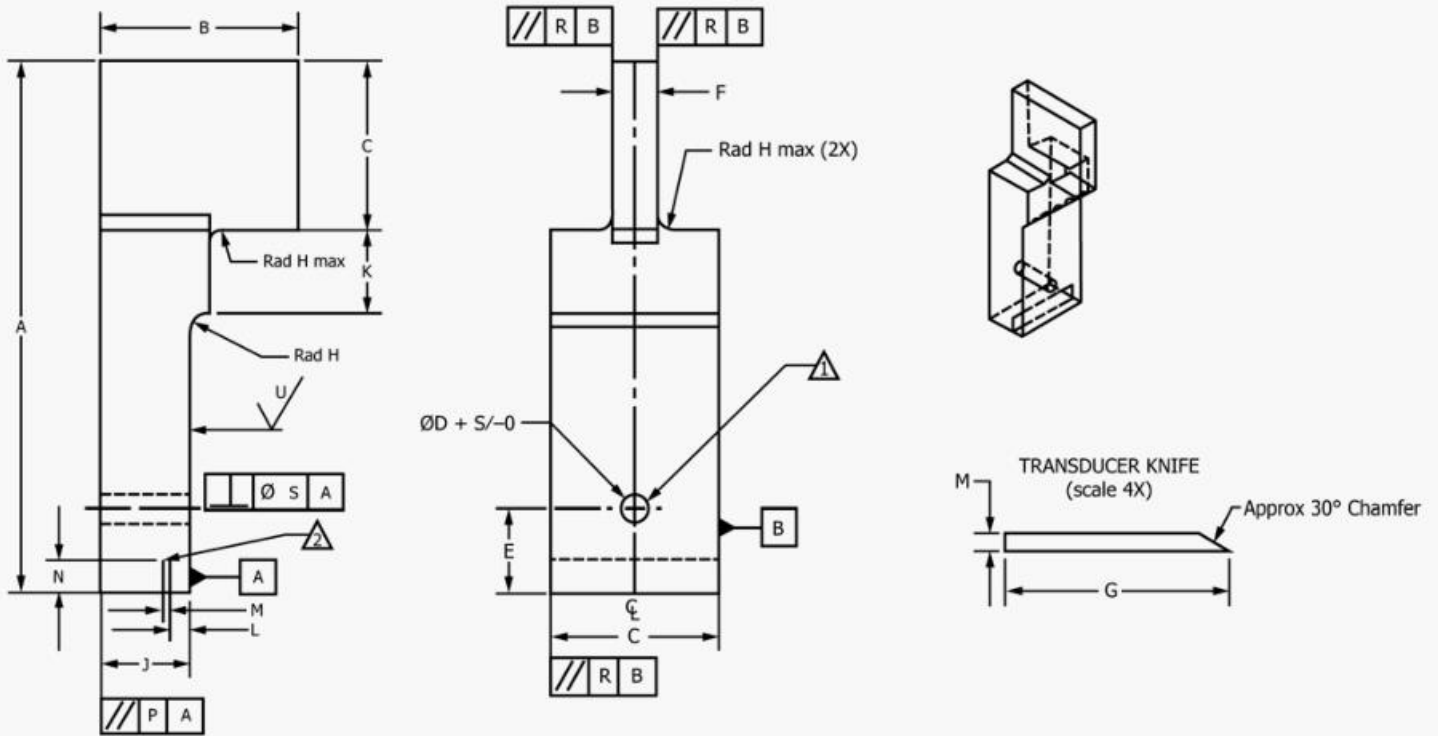

	A	B	C	D	E	F	G	H	J	K	L	M	N	P	Q	R	S	T	U	
SI (mm)	120.0	42.0	36.0	6.00	18.0	10.0	13.0	3.0	20.55	19.0	5.0	1.00	7.6	0.13	0.3	0.1	0.03/-0.0	micro m	0.8	3.2
US (in)	4.75	1.75	15	0.250	0.75	0.4	0.5	0.13	0.805	0.75	0.20	0.04	0.3	0.005	0.03	0.01	0.001/-0.0	micro in	32	125

NOTES:

- Hole may be bushed with press-fit high strength bushing to prevent fixture hole deformation. Bushing must be ground flush to fixture face and have constant ID with no chamfer at hole edges.
 - Transducer knife press fit into slot as shown in Figure 11.
- Material is 1.1 GPa [160 ksi] minimum steel.
 - Tolerances unless otherwise noted are: (SI X.X±Q, X.XX±R) (US X.XX±Q, X.XXX±R)
 - Surface finish unless otherwise noted is: T

FIG. 10 One-Piece Single-Shear Test Fixture for Procedure C

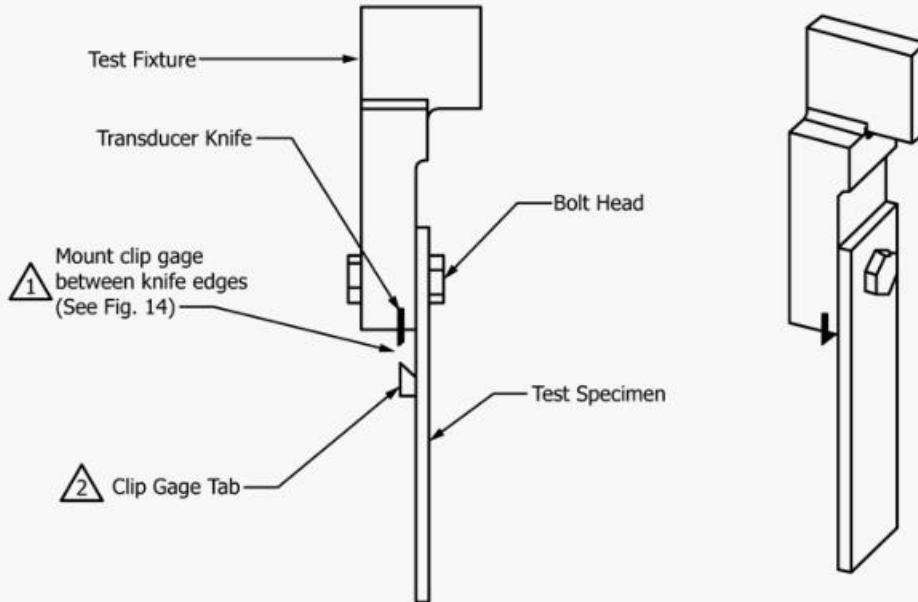

NOTES:

- Knife blade tip and clip gage tab tip shall be co-planar ± Q (see Figure 10)
- Manufacture clip gage tab from suitable material such that deformation or other damage to the tab is prevented. Clamp or bond (with suitable adhesive) clip gage tab to specimen as appropriate for clip gage and test environment, taking care not to damage specimen or interfere with load introduction.

FIG. 11 One-Piece Single-Shear Test Set-Up (Procedure C)

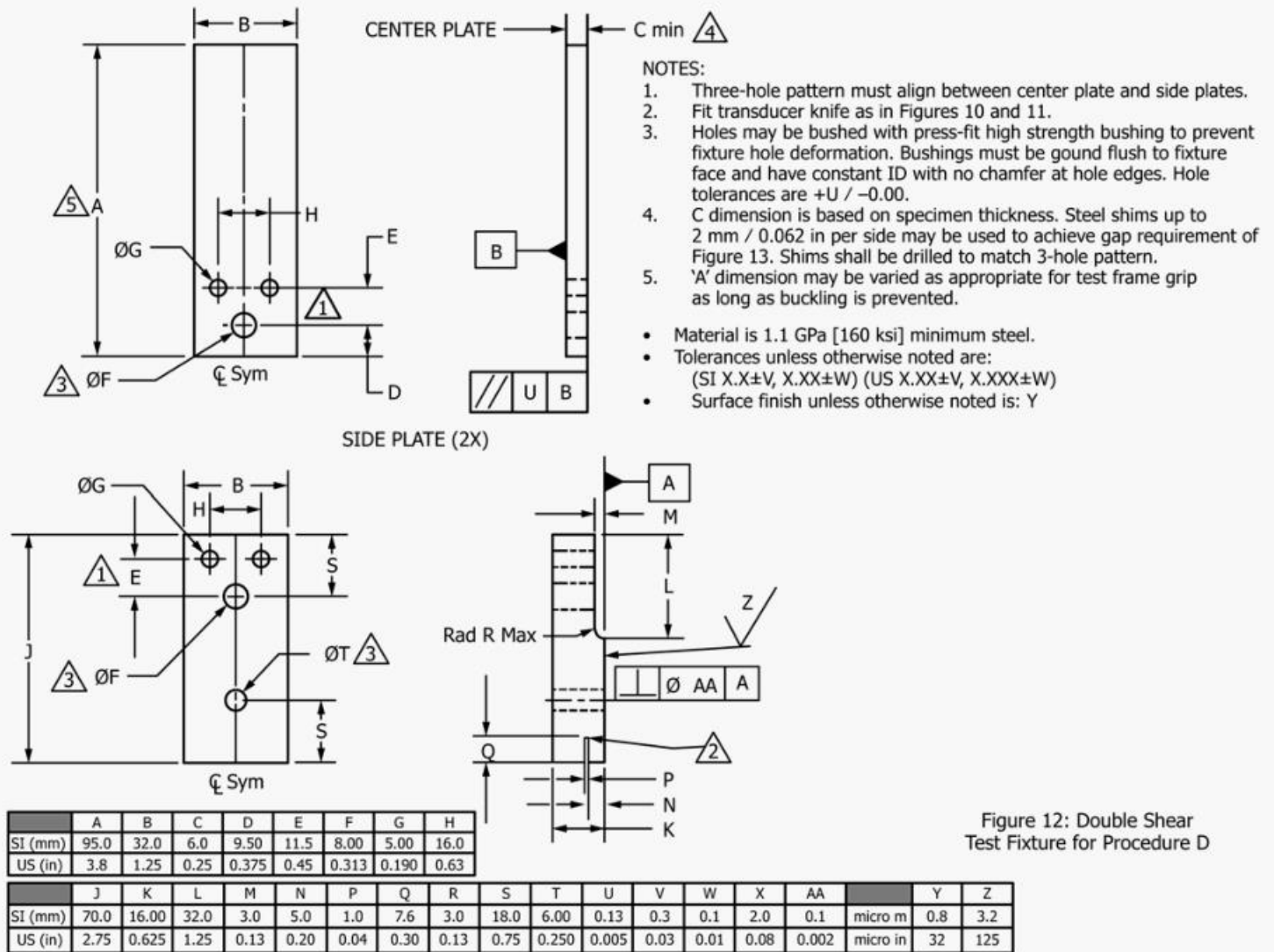

Figure 12: Double Shear Test Fixture for Procedure D

FIG. 12 Double-Shear Compression Test Fixture for Procedure D

contact surface feature (e.g., inner and outer diameters) and pin bending distribution (e.g., boss height) must be maintained through use of a suitable washer. The fixture shall allow a bearing strain indicator to monitor the hole deformation relative to the fixture as shown in Fig. 14.

7.3.2 Procedure B—The force shall be applied to the one- or two-fastener two-piece specimen either by directly gripping in the test frame grips, or by means of an optional support fixture, as shown in Fig. 9. The line of action of the force shall be adjusted by specimen doublers to be coincident and parallel to the interface between the test specimen halves. Support fixture details are described in 7.4. The assembled two-piece test specimen and support fixture (if used) will allow a bearing strain indicator to measure the required hole deformation between specimen halves, as shown in Fig. 14.

7.3.3 Procedure C—The force shall be applied to the specimen by means of a single-shear fixture similar to that shown in Figs. 10 and 11, using a single loading fastener. The fixture shall allow a bearing strain indicator to monitor the hole deformation, as shown in Fig. 14.

7.3.4 Procedure D—The force shall be applied to the specimen by means of a double-shear clevis similar to that

shown in Figs. 12 and 13, using a single loading fastener or pin. For torqued tests, the clevis shall allow a torqued fastener to apply a transverse compressive force to the specimen around the periphery of the hole. The fixture shall provide adequate column buckling stability such that essentially no loading eccentricity occurs. The fixture shall allow a bearing strain indicator to monitor the hole deformation, as shown in Fig. 14.

7.4 Procedure B Support Fixture—If compressive forces are applied, a support fixture shall be used to stabilize the specimen. The fixture is a face-supported test fixture as shown in Fig. 9. The fixture consists of two short-grip/long-grip assemblies, two support plates, and stainless steel shims as required to maintain a nominally zero (0.00 to 0.12-mm [0.000 to 0.005-in] tolerance) gap between the support plates and the long grips. If this gap does not meet the minimum requirement, shim the contact area between the support plate and the short grip with brass, aluminum, or stainless steel shim stock. If the gap is too large, shim between the support plate and the long grip, holding the shim stock on the support plate with tape. Fig. 15 shows shim requirements. The fixture should be checked for conformity to engineering drawings. Each short-grip/long-grip

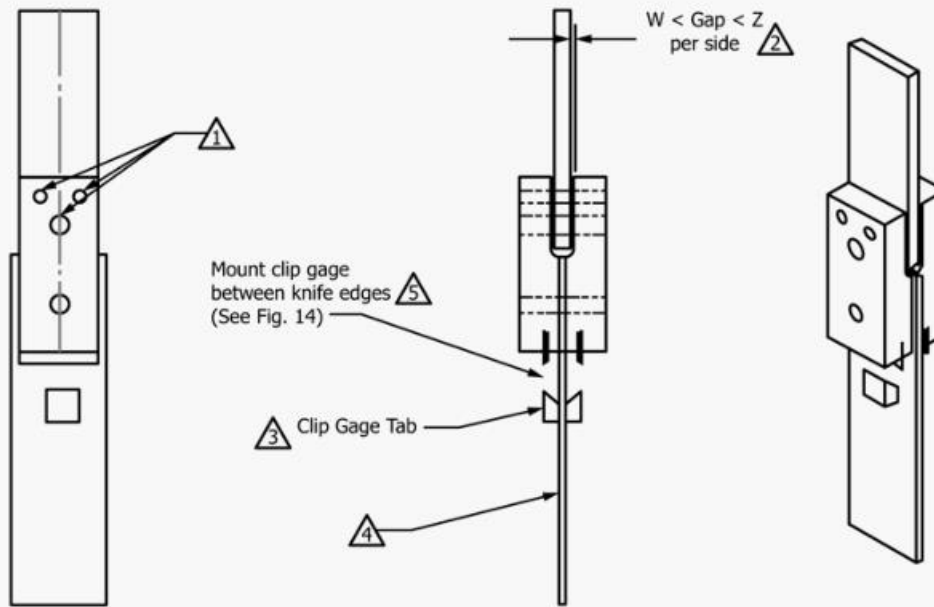

NOTES:

Specimen length may be shortened to prevent buckling.

1. Assemble fixture with constant diameter pins (3x), not fasteners. Pin to hole clearance shall not exceed V (see Fig 12). The only torqued fastener shall be the fastener through the specimen.
2. Shims may be used to control gap (see note on Figure 13).
3. Manufacture clip gage tab from suitable material such that deformation or other damage to the tab is prevented. Clamp or bond (with suitable adhesive) clip gage tab to specimen as appropriate for clip gage and test environment, taking care not to damage specimen or interfere with load introduction.
4. Minimize unsupported specimen length when gripping in order to prevent buckling. Specimen length may be shortened if necessary.
5. Knife blade tip and clip gage tab tip shall be co-planar $\pm V$ (see Figure 12).

FIG. 13 Double-Shear Compression Test Set-Up (Procedure D)

assembly is line-drilled as shown in Figs. 16 and 17 and must be used as a matched set. The threading of the support plate is optional. Standard test specimens for single- and multiple-fastener configurations are 36 by 340 mm [1.5 by 13.5 in.] to allow testing of both configurations in the same support fixture. The fixture is hydraulically gripped on each end and the force is sheared by means of friction through the fixture and into the test specimen. A cutout exists on both faces of the fixture for a thermocouple, fastener(s) and surface-mounted extensometer, and the width of the long grip face is less than that of the test specimen to accommodate edge-mounted extensometry. The long and short fixtures have an undercut along the corner of the specimen grip area so that specimens are not required to be chamfered and to avoid damage caused by the radius. The fixtures also allow a slight clearance between the fixture and the gage section of the specimen, in order to minimize grip failures and friction effects.

7.4.1 Procedure B Support Fixture Details—The detailed drawings for manufacturing the support fixture are contained in Figs. 18-25. An optional threaded support plate is shown in Figs. 26 and 27, to be used instead of the support plate shown in Figs. 24 and 25 and the nuts called out in Fig. 9. Other fixtures that meet the requirements of this section may be used. The following general notes apply to these figures:

7.4.1.1 Machine surfaces to a 3.2 [125] finish unless otherwise specified.

7.4.1.2 Break all edges.

7.4.1.3 Specimen-gripping area shall be thermal sprayed with tungsten-carbide particles using high-velocity oxygen fueled (HVOF), electrospark deposition (ESD), or equivalent process.

7.4.1.4 The test fixture may be made of low-carbon steel for ambient temperature testing. For non-ambient environmental conditions, the recommended fixture material is a nonheat-treated ferritic or precipitation-hardened stainless steel (heat treatment for improved durability is acceptable but not required).

NOTE 3—Experience has shown that all of the fixtures described in 7.3 and 7.4 may be damaged in use, thus periodic re-inspection of the fixture dimensions and tolerances is important. Fig. 18 Fig. 19 Fig. 20 Fig. 21 Fig. 22 Fig. 23 Fig. 24 Fig. 25 Fig. 26 Fig. 27

7.5 Testing Machine—The testing machine shall be in conformance with Practices E4, and shall satisfy the following requirements:

7.5.1 Testing Machine Configuration—The testing machine shall have both an essentially stationary head and a movable head. A short loading train and rigidly mounted hydraulic grips shall be used for Procedure B using the support fixture, Procedure C, and Procedure D.

7.5.2 Drive Mechanism—The testing machine drive mechanism shall be capable of imparting to the movable head a controlled velocity with respect to the stationary head. The velocity of the movable head shall be capable of being regulated as specified in 11.4.

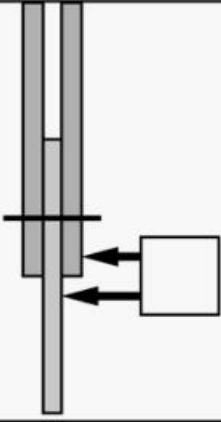
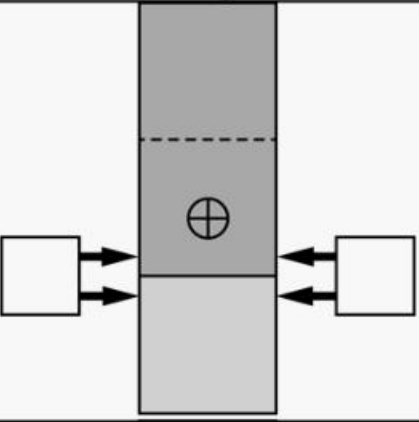
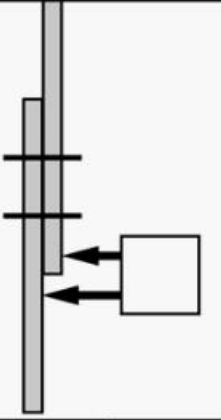
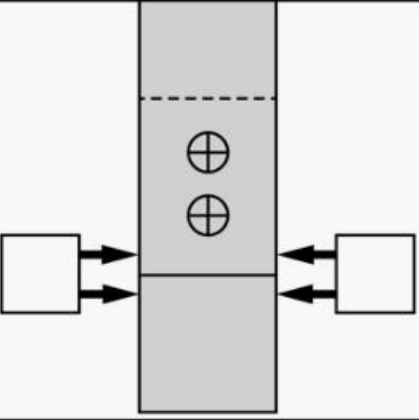
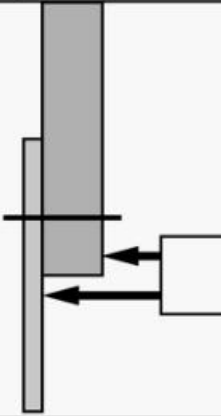
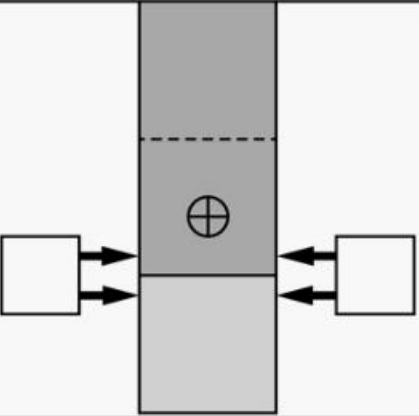
Procedures	Face-Mounted	Edge-Mounted
A or D		
B		
C		

Notes:

1. Either one or two edge-mounted extensometers is/are acceptable.
2. Edge-mounting requires one extensometer arm to contact the specimen and the other the test fixture (or other segment of the test specimen, in Procedure B).
3. Extensometer(s) shall be attached to the specimen and fixture using best laboratory practices (mechanically attached or adhesively-bonded tabs are most common).

FIG. 14 Transducer Gage Length and Location

7.5.3 Force Indicator—The testing machine force-sensing device shall be capable of indicating the total force being carried by the test specimen. This device shall be essentially free from inertia-lag at the specified rate of testing and shall indicate the force with an accuracy over the force range(s) of interest of within $\pm 1\%$ of the indicated value.

7.5.4 Grips—Each head of the testing machine shall be capable of holding one end of the test assembly so that the direction of force applied to the specimen is coincident with the longitudinal axis of the specimen. Wedge grips shall apply sufficient lateral pressure to prevent slippage between the grip face and the test specimen or support fixture.

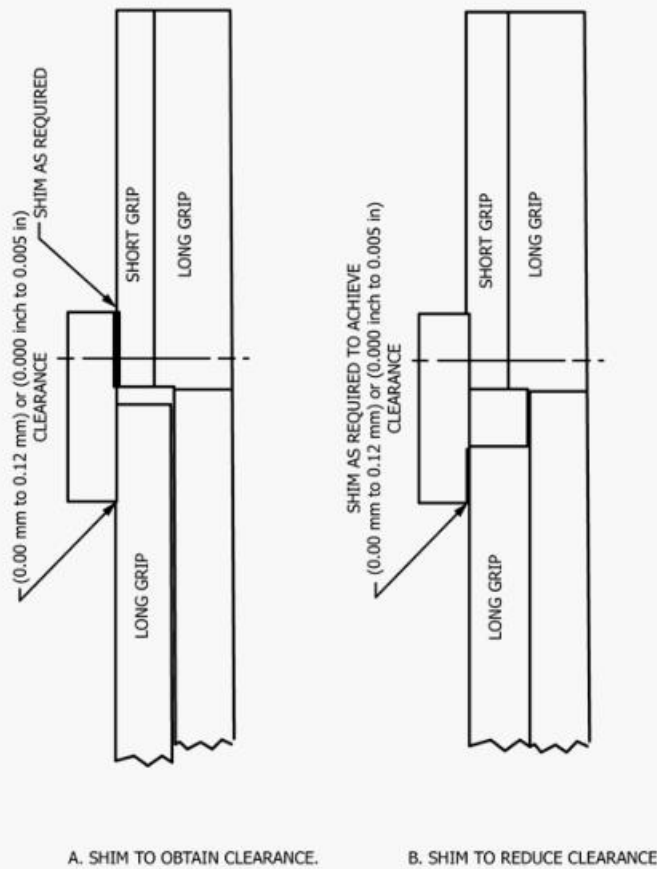

FIG. 15 Support Fixture-Shim Requirements

7.6 *Bearing Strain Indicator*—Bearing strain data shall be determined by one or two bearing strain indicators capable of measuring longitudinal hole deformation, as shown in Fig. 14. Note that face-mounted extensometry is not possible for Procedure B when the optional support fixture is used. Attachment of the bearing strain indicator(s) to the specimen shall not cause damage to the specimen surface. Transducers shall satisfy, at a minimum, Practice E83, Class B-2 requirements for the bearing strain/displacement range of interest, and shall be calibrated over that range in accordance with Practice E83. The transducers shall be essentially free of inertia lag at the specified speed of testing.

NOTE 4—While not shown in Fig. 14, a matched set of extensometers mounted on opposite faces would be required to quantify and correct for out-of-plane joint rotation in an unstabilized single-shear loading configuration.

7.6.1 *Torque Wrench*—If using a torqued fastener, a torque wrench used to tighten a joint fastener shall be capable of determining the applied torque to within $\pm 10\%$ of the desired value.

7.7 *Environmental Test Chamber*—An environmental test chamber is required for test environments other than ambient testing laboratory conditions. This chamber shall be capable of maintaining the gage section of the test specimen at the required test environment during the mechanical test.

8. Sampling and Test Specimens

8.1 *Sampling*—Test at least five specimens per test condition unless valid results can be gained through the use of fewer

specimens, as in the case of a designed experiment. For statistically significant data the procedures outlined in Practice E122 should be consulted. The method of sampling shall be reported.

NOTE 5—If specimens are to undergo environmental conditioning to equilibrium, and are of such type or geometry that the weight change of the material cannot be properly measured by weighing the specimen itself (such as a tabbed mechanical specimen), then use a traveler specimen of the same nominal thickness and appropriate size (but without tabs) to determine when equilibrium has been reached for the specimens being conditioned.

8.2 Test Specimen Geometry:

8.2.1 *Stacking Sequence*—The standard laminate shall have multidirectional fiber orientations (fibers shall be oriented in a minimum of two directions), and balanced and symmetric stacking sequences. Nominal thickness shall be as close as possible to 4 mm [0.16 in.], with a permissible range from 2 to 4 mm [0.08 to 0.17 in.], inclusive, for a 6 mm [0.250 in.] diameter pin or fastener. Fabric laminates containing satin-type weaves shall have symmetric warp surfaces, unless otherwise specified and noted in the report.

NOTE 6—Typically, a $[45/0/-45/90]_{ms}$ tape or $[45/0]_{ms}$ fabric laminate should be selected such that a minimum of 5% of the fibers lay in each of the four principal orientations. This laminate design has been found to yield the highest likelihood of acceptable failure modes.

8.2.2 Configuration:

8.2.2.1 *Procedures A, C, and D*—The geometry of the specimen for Procedures A, C, and D is shown in Figs. 1 and 2. For Procedure D, it is acceptable to reduce the overall

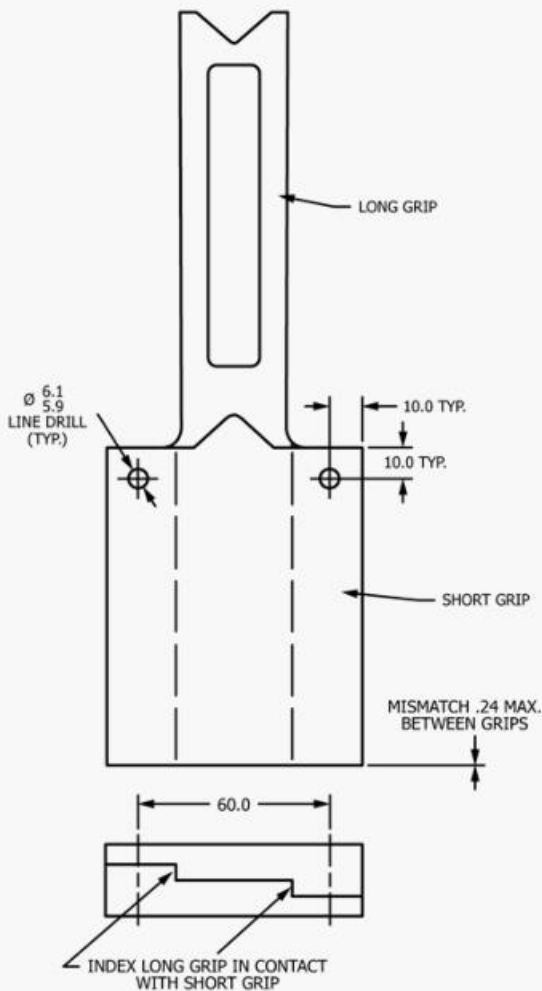

FIG. 16 Support Fixture-Line Drilling Details (SI)

specimen length as required to prevent buckling of the unsupported segment between the bearing fixture and the specimen grip. Maximum unsupported length may be estimated using Table 3 in Test Method D3410/D3410M, or similar buckling analysis methods.

8.2.2.2 Procedure B—The geometry of the specimen for Procedure B is shown in Figs. 5 and 6 for a single-fastener joint and Figs. 7 and 8 for a double-fastener joint. Note that the countersink(s) shown in the drawings is optional. For a double-fastener configuration, extend the length of each specimen half by the required distance and place a second bearing hole in line with the first, as shown in Figs. 7 and 8. If the

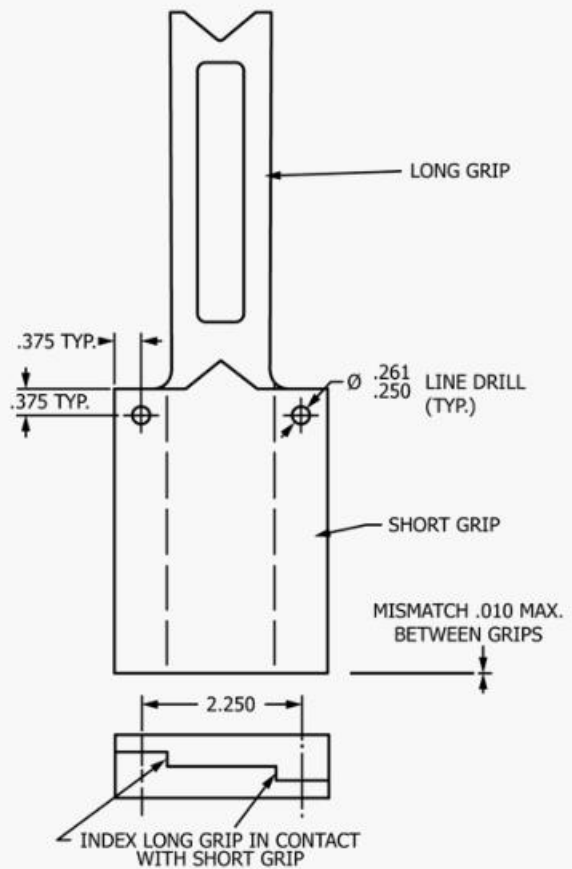
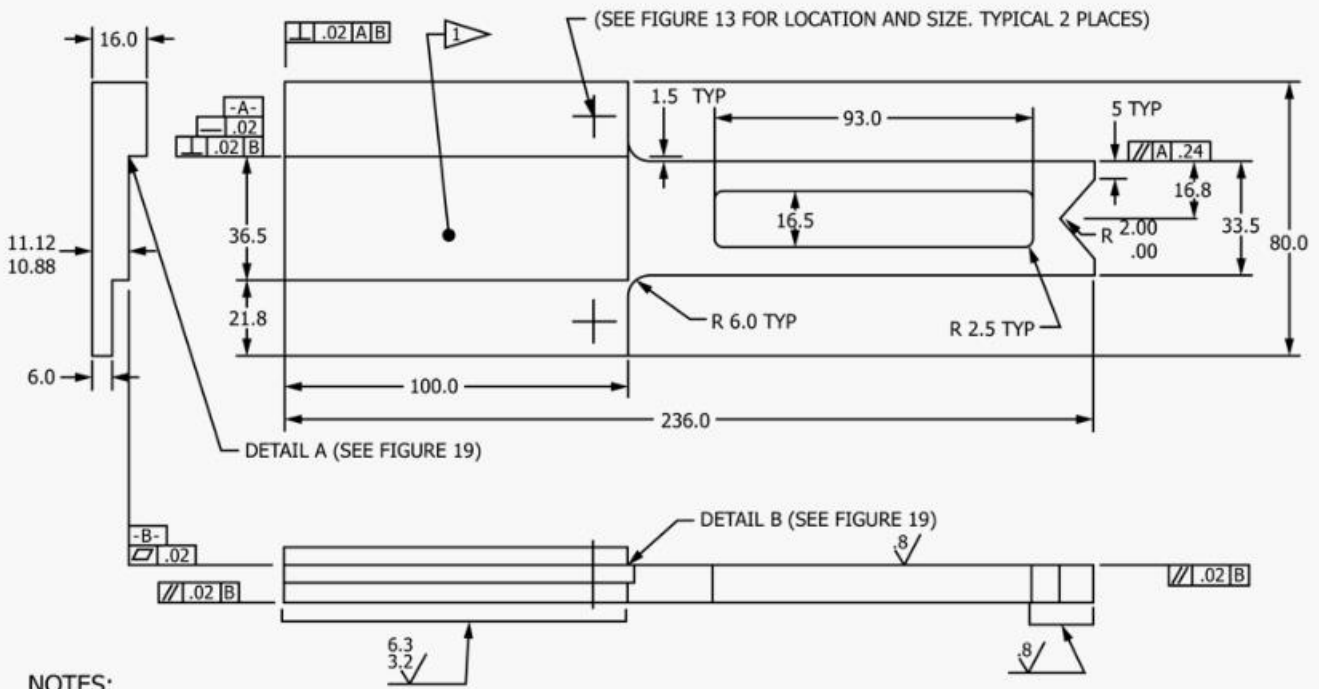

FIG. 17 Support Fixture-Line Drilling Details (Inch-Pound)

double-fastener specimen is using countersunk fasteners, one countersink should be located on each side of the specimen, as shown. Note that if the support fixture is used for either the single- or double-fastener specimen configuration, the length of each specimen half and doubler must be adjusted as shown in Figs. 5-8 to accommodate loading with the fixture.

NOTE 7—When the double-fastener specimen is using countersunk fasteners, the countersink as shown is located on opposing faces of the specimen in order to provide an exact 50:50 force split between the two fasteners. This configuration has the potential to produce a net section failure mode at the first fastener (nearest the grips) rather than a pure bearing failure mode. As the scope of this test method is limited to bearing response, a net section failure mode at the first fastener location shall be clearly noted in the report and is cause for declaring the bearing test value invalid. If an alternate configuration, such as locating the countersink for both fasteners on the same face of the specimen, is desired to better represent an actual structural joint, the deviation shall be clearly noted in the test report.



NOTES:

1. Thermal spray surface using high velocity oxygen fueled (HVOF) process or electrospark deposition (ESD) process.
2. Tolerance except as noted is linear ± 0.3 mm.

FIG. 18 Support Fixture-Long Grip Details (SI)

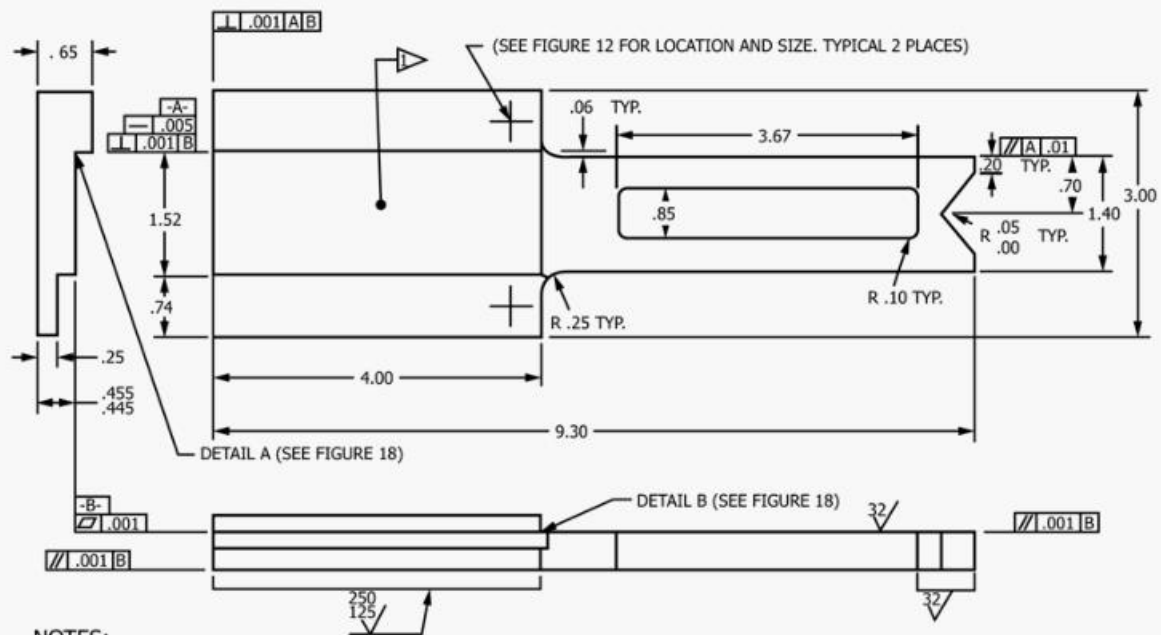

NOTES:

1. Thermal spray surface using either high velocity oxygen fueled (HVOF) process or electrospark deposition (ESD) process.
2. Tolerance except as noted is linear ± 0.03 in.

FIG. 19 Support Fixture-Long Grip Details (Inch-Pound)

8.2.3 *Doubler Material*—The use of doublers made from the same laminate as the specimen being tested is recommended for all single-shear tests, as this ensures that the

doublers are the same thickness as the laminate being tested, which is critical for proper loading of the single-shear test configuration.

ASIM D5961/D5961M - 13

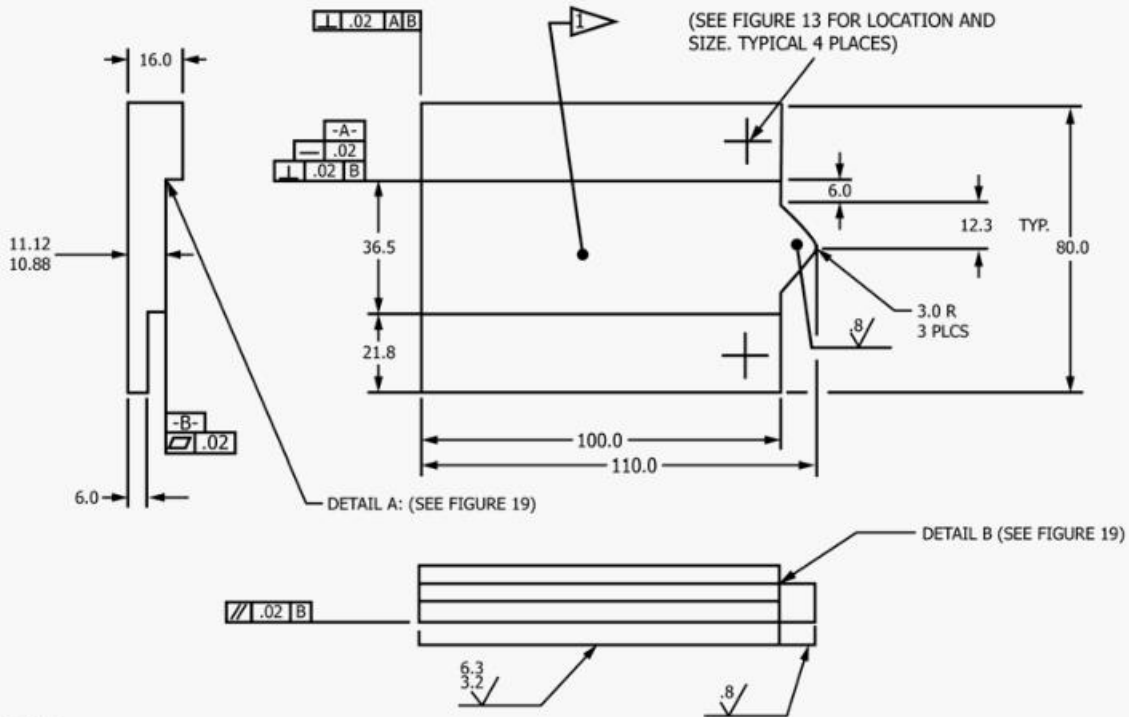

NOTES:

1. Thermal spray surface using either high velocity oxygen fueled (HVOF) process or electrospark deposition (ESD) process.

2. Tolerance except as noted is linear $\pm.3$ mm.

FIG. 20 Support Fixture-Short Grip Details (SI)

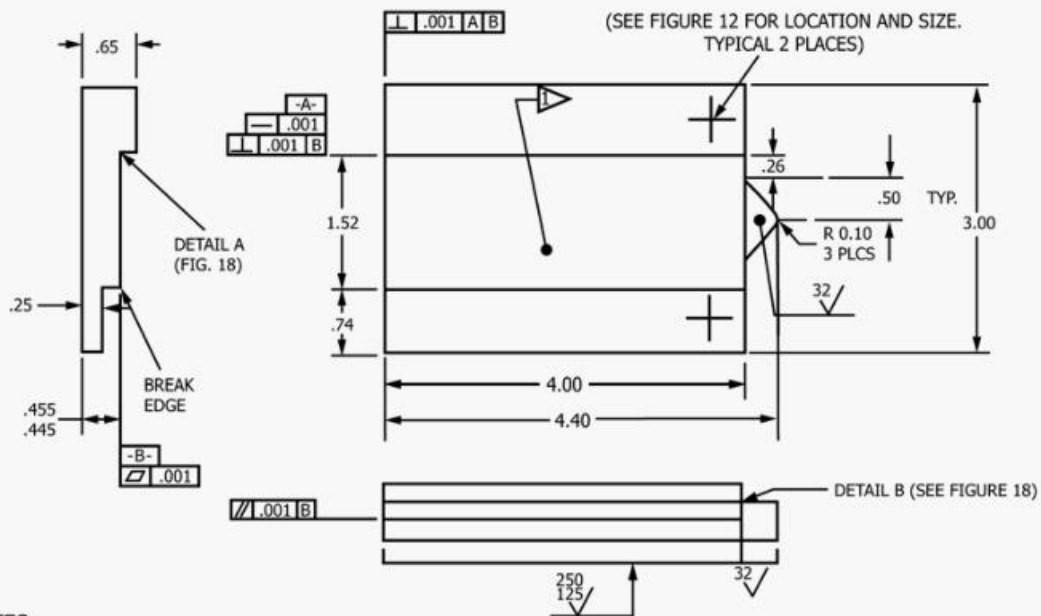

NOTES:

1. Thermal spray using either high velocity oxygen fueled (HVOF) process or electrospark deposition (ESD) process.

2. Tolerance except as noted is linear $\pm.03$ in.

FIG. 21 Support Fixture-Short Grip Details (Inch-Pound)

8.2.4 Adhesive—Any high-elongation (tough) adhesive system that meets the environmental requirements may be used

when bonding doublers to the material under test. A uniform

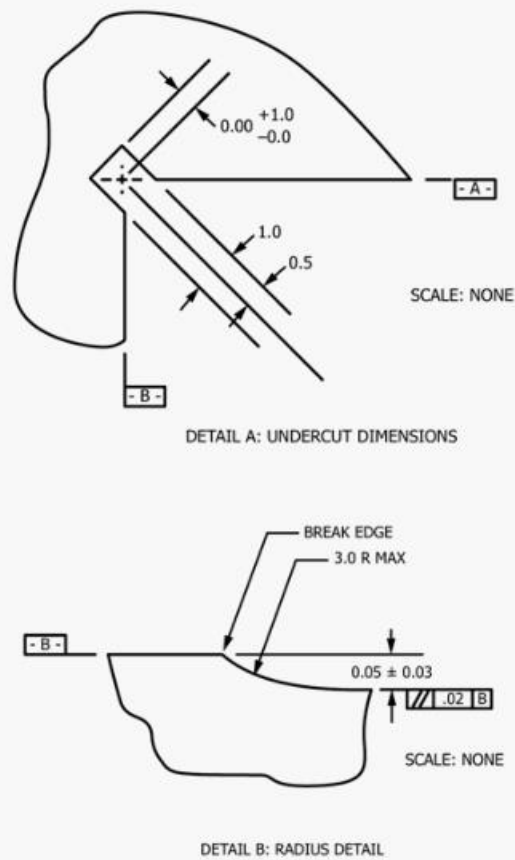

FIG. 22 Support Fixture-Details A and B (SI)

bondline of minimum thickness is desirable to reduce undesirable stresses in the assembly.

8.3 *Specimen Preparation*—Guide [D5687/D5687M](#) provides recommended specimen preparation practices and should be followed where practical.

8.3.1 *Panel Fabrication*—Control of fiber alignment is critical. Improper fiber alignment will reduce the measured properties. The panel(s) must be flat and of uniform thickness to ensure even loading. Erratic fiber alignment will also increase the coefficient of variation. Report the panel fabrication method.

8.3.2 *Machining Methods*—Preparation is extremely important for this specimen. Take precautions when cutting specimens from plates in order to avoid creating notches, undercuts, rough or uneven surfaces, or delaminations due to inappropriate machining methods. Obtain final dimensions by water-lubricated precision sawing, milling, or grinding. The use of diamond tooling has been found to be extremely effective for many material systems. Edges should be flat and parallel within the specified tolerances. Holes should be drilled undersized and reamed to final dimensions. Special care shall be taken to ensure that creation of the specimen hole does not delaminate or otherwise damage the material surrounding the hole. Machining tolerances and surface finish requirements are as noted in [Figs. 1 and 2](#), and [Figs. 5-8](#). Record and report the specimen cutting and hole preparation methods.

8.3.3 *Labeling*—Label the specimens so that they will be distinct from each other and traceable back to the raw material, and in a manner that will both be unaffected by the test and not influence the test.

9. Calibration

9.1 The accuracy of all measuring equipment shall have certified calibrations that are current at the time of use of the equipment.

10. Conditioning

10.1 The recommended pre-test specimen condition is effective moisture equilibrium at a specific relative humidity as established by Test Method [D5229/D5229M](#); however, if the test requester does not explicitly specify a pre-test conditioning environment, no conditioning is required and the test specimens may be tested as prepared.

10.2 The pre-test specimen conditioning process, to include specified environmental exposure levels and resulting moisture content, shall be reported with the data.

NOTE 8—The term *moisture*, as used in Test Method [D5229/D5229M](#), includes not only the vapor of a liquid and its condensate, but the liquid itself in large quantities, as for immersion.

10.3 If no explicit conditioning process is performed the specimen conditioning process shall be reported as “unconditioned” and the moisture content as “unknown.”

11. Procedure

11.1 *Parameters to Be Specified Prior to Test:*

11.1.1 The specimen sampling method, specimen type and geometry, fastener type and material, countersink angle and depth (if appropriate), fastener clamp-up torque (if appropriate), use of washers (if appropriate), support fixture (if appropriate), loading mode (tensile or compressive), cleaning process, and conditioning travelers (if required).

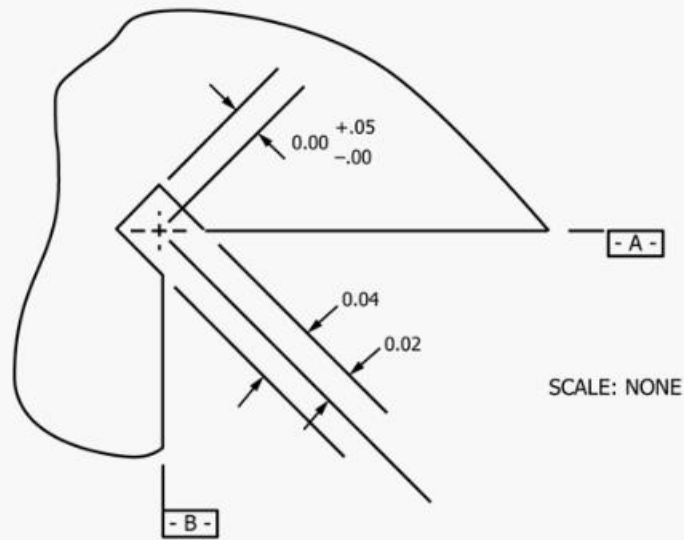

SCALE: NONE

DETAIL A: UNDERCUT DIMENSIONS

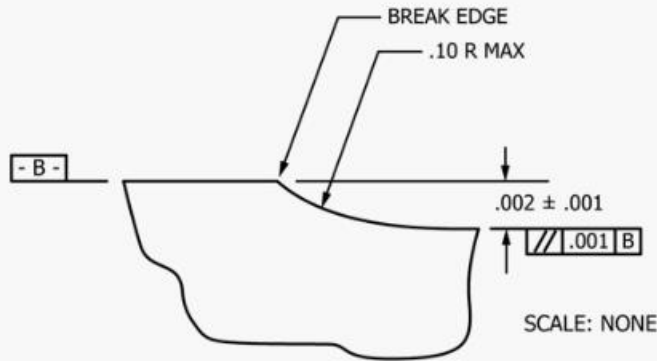

SCALE: NONE

DETAIL B: RADIUS DETAIL

FIG. 23 Support Fixture-Details A and B (Inch-Pound)

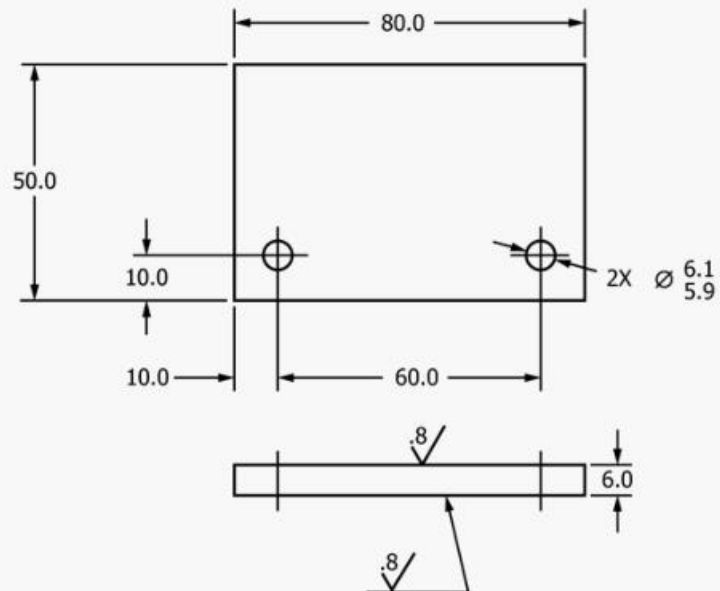

FIG. 24 Support Fixture-Support Plate Details (SI)

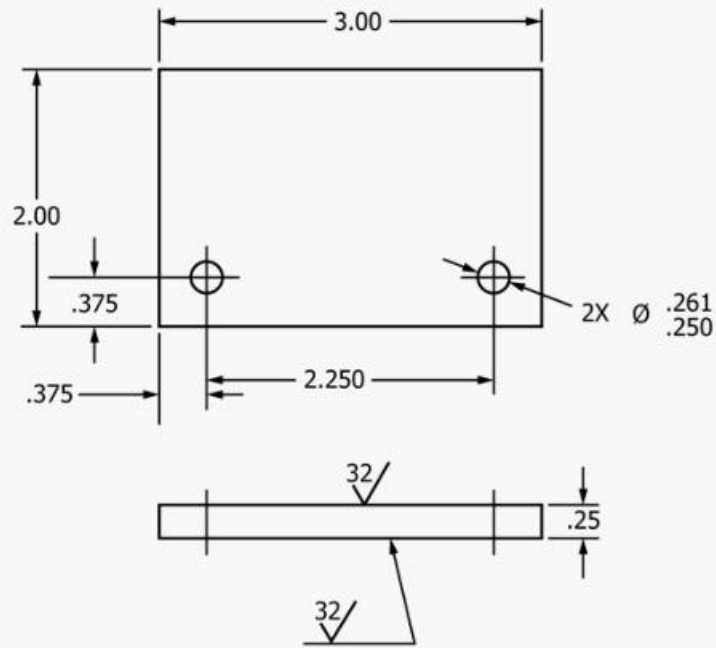

FIG. 25 Support Fixture-Support Plate Details (Inch-Pound)

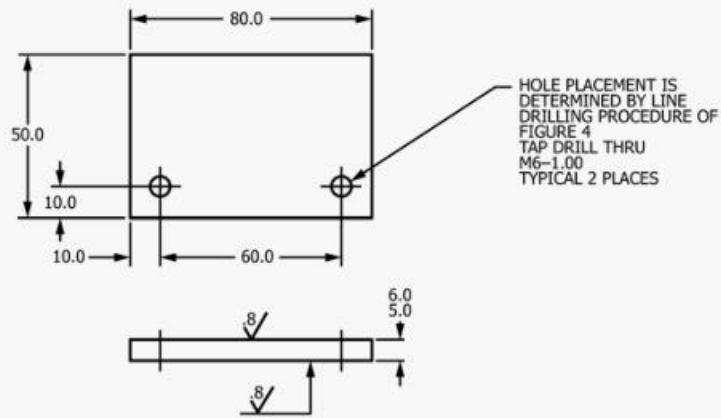

FIG. 26 Support Fixture-Optional Threaded Support Plate Details (SI)

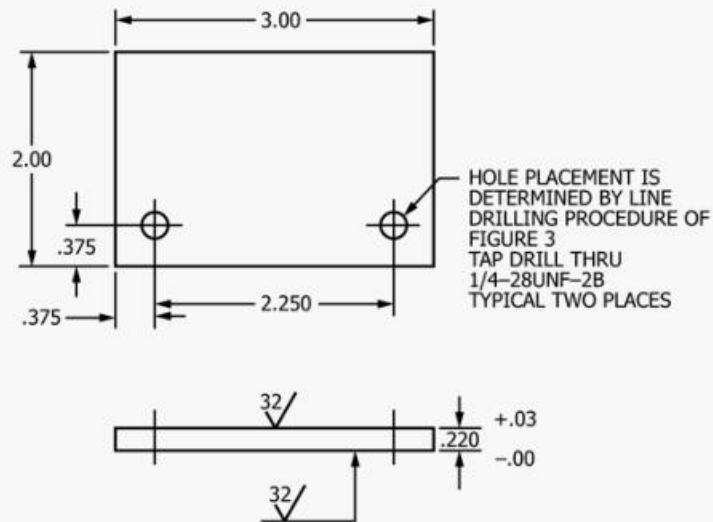

FIG. 27 Support Fixture-Optional Threaded Support Plate Details (Inch-Pound)

11.1.2 The bearing properties, offset bearing strain value and data reporting format desired.

NOTE 9—Unless otherwise specified, an offset bearing strain of 2 % shall be used.

NOTE 10—Determine specific material property, accuracy, and data reporting requirements prior to test for proper selection of instrumentation and data recording equipment. Estimate operating bearing stress and bearing strain levels to aid in transducer selection, calibration of equipment, and determination of equipment settings.

11.1.3 The environmental conditioning test parameters.

11.1.4 Extensometry/bearing strain indicator requirements and related calculations.

11.1.5 If performed, the sampling method, specimen geometry, and test parameters used to determine density and reinforcement volume.

11.2 *General Instructions:*

11.2.1 Report any deviations from this test method, whether intentional or inadvertent.

11.2.2 If specific gravity, density, reinforcement volume, or void volume are to be reported, then obtain these samples from the same panels being bearing tested. Specific gravity and density may be evaluated by means of Test Methods **D792**. Volume percent of the constituents may be evaluated by one of the matrix digestion procedures of Test Method **D3171**, or, for certain reinforcement materials such as glass and ceramics, by the matrix burn-off technique of Test Method **D2584**. The void content equations of Test Method **D2734** are applicable to both Test Method **D2584** and the matrix digestion procedures.

11.2.3 Condition the specimens as required. Take appropriate measures to prevent specimen moisture loss or gain during the transition from the conditioning environment to the test environment.

11.2.4 Following final specimen machining and any conditioning, but before bearing testing, measure the specimen width, w , and the specimen thickness, h , in the vicinity of the hole. Measure the hole diameter, D , distance from hole edge to closest specimen side, f , and distance from hole edge to specimen end, g . Measure the fastener or pin diameter, d , at the bearing contact location, the countersink depth, d_{csk} (if appropriate), and the countersink flushness, d_f (if appropriate). The accuracy of all measurements shall be within 1% of the dimension, unless otherwise specified in this test method. Record the dimensions to three significant figures in units of millimeters [inches].

11.2.5 *Cleaning*—Clean the specimen hole, surrounding clamping area, and fastener or pin shank. If the fastener threads are required to be lubricated, apply the lubricant to the nut threads instead of the fastener threads and take extreme care not to accidentally transfer any of the lubricant to the fastener shank, the specimen hole, or to the clamping area during assembly and torquing. Record and report cleaning method and lubricant used, if any.

11.2.6 *Specimen Assembly*—Assemble the test specimen to mating specimen or test fixture as appropriate for the procedure, with fastener or pin (and washers if utilized). For Procedure D ensure that the ungripped length of the test specimen (hole center to edge of grip) is sufficient to preclude buckling (no more than 25 mm [1.0 in.] for a typical carbon fiber-reinforced polymer matrix composite in the baseline specimen configuration).

11.3 *Fastener Torquing*—If using a torqued fastener, tighten the fastener to the required clamp-up value using a calibrated torque wrench. Record and report the actual total and run-on torque values.

NOTE 11—Take care not to work the joint after torquing. Joint rotation after torquing and before and during insertion into the testing machine may relax the initial torque. Final torquing of the fastener may be necessary after the specimen is inserted into the test machine.

11.4 *Test Procedure:*

11.4.1 *Speed of Testing*—Set the speed of testing so as to produce failure within 1 to 10 min. If the ultimate bearing strain of the material cannot be reasonably estimated, initial trials should be conducted using standard speeds until the ultimate bearing strain of the material and the compliance of the system are known, and speed of testing can be adjusted. The suggested standard speeds are:

11.4.1.1 *Bearing Strain-Controlled Tests*—A standard bearing-strain rate of 0.01 min^{-1} .

11.4.1.2 *Constant Head-Speed Tests*—A standard head displacement rate of 2 mm/min [0.05 in./min].

11.4.2 *Test Environment*—If possible, test the specimen under the same fluid exposure level used for conditioning. However, cases such as elevated temperature testing of a moist specimen place unrealistic requirements on the capabilities of common testing machine environmental chambers. In such cases the mechanical test environment may need to be modified, for example, by testing at elevated temperature with no fluid exposure control, but with a specified limit on time to failure from withdrawal from the conditioning chamber. Record any modifications to the test environment.

11.4.3 *Specimen Installation:*

11.4.3.1 *Procedures A, B (No Support Fixture), and C*—Insert the specimen into the test machine, attaching loading interfaces or tightening grips as required.

11.4.3.2 *Procedure B (With Support Fixture)*—Install the test specimen into the support fixture such that the machined ends of the specimen are flush with the ends of the fixture halves. This should result in the specimen hole(s)/fastener(s) being centered in the fixture cutout. Tighten the four bolts just enough to hold the specimen in place during fixture installation.

11.4.3.3 *Procedure D*—Install the test specimen into the fixture as shown in **Fig. 13**.

11.4.4 *Fixture Insertion (Procedure B With Support Fixture):*

11.4.4.1 Place the fixture in the grips of the testing machine, taking care to align the long axis of the gripped fixture with the test direction. When inserting the fixture into the grip-jaws, grip the outer portion of the fixture as deeply into the grips as possible.

11.4.4.2 Tighten the grips, recording the pressure used on the hydraulic grips. The ends of the grip-jaws on wedge-type grips should be even with each other following insertion to avoid inducing a bending moment which could result in premature failure of the specimen.

11.4.4.3 Retorque the four bolts to approximately 7 N·m [60 lbf·in.] after hydraulic gripping pressure is applied.

11.4.4.4 Check the gaps between the support plates and the long grip portion of the support fixture using a feeler gage, and shim as required in Fig. 15.

11.4.4.5 Check that the gap between the gage section of the specimen and the long grip portion of the support fixture is 0.05 ± 0.05 mm [0.002 ± 0.002 in.] using a feeler gage (see Fig. 28). A gap outside of this tolerance range is indicative of either misaligned grips, improper assembly, an out-of-tolerance specimen, damaged fixtures, or a combination thereof.

11.4.5 Fixture Insertion (Procedure D):

11.4.5.1 Place the specimen/fixture assembly in the grips of the testing machine, taking care to align the long axis of the gripped assembly with the test direction. When inserting the specimen/fixture assembly into the grip-jaws, grip the center plate portion of the fixture as deeply into the grips as possible and grip the specimen end of the assembly such that the unsupported specimen length is minimized in order to prevent buckling.

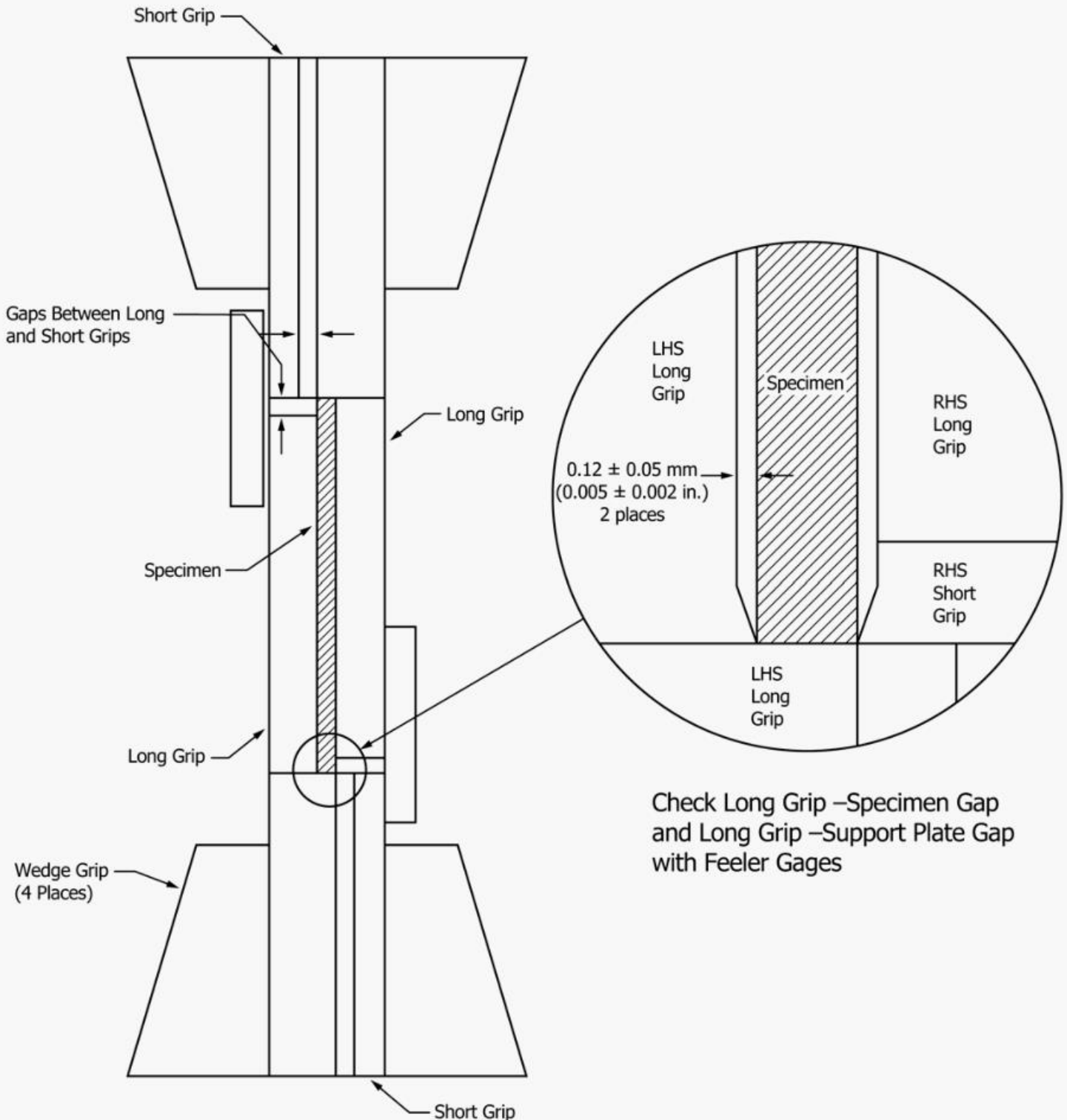

FIG. 28 Specimen/Support Fixture/Grip Assembly for Procedure B

11.4.5.2 Tighten the grips, recording the pressure used on the hydraulic grips. The ends of the grip-jaws on wedge-type grips should be even with each other following insertion to avoid inducing a bending moment which could result in premature failure of the specimen.

11.4.6 *Complete Bearing Strain Indicator Installation*—Attach the bearing strain indicator(s) to the specimen as shown in Fig. 10, Fig. 12, or Fig. 14 to provide the average displacement across the loaded hole(s). Attach the recording instrumentation to the indicator. Remove any remaining pre-load and zero the indicator.

11.4.7 *Loading*—Apply the force to the specimen at the specified rate while recording data. The specimen is loaded until a maximum force is reached and force has dropped off about 30 % from the maximum, or displacement equal to half of the hole diameter has occurred. Unless specimen rupture is specifically desired, the test is terminated following this drop in force or achieving this displacement so as to prevent masking of the true failure mode by large-scale hole distortion, in order to provide a more representative failure mode assessment and to prevent support fixture damage (if used). In compression loading, excessive deformation may occur such that a maximum force may not be obvious and two piece failure may not occur. Care should be taken in Procedures B and D, when conducted under compressive loading, to ensure that the stabilization plates do not self-contact by terminating compression test loading when head displacement has reached a maximum of 4.5 mm [0.18 in.] (90 % nominal end gap distance) to prevent support fixture damage.

11.4.8 *Data Recording*—Record force versus bearing strain (or hole displacement) continuously, or at frequent regular intervals. For this test method, a sampling rate of 2 to 3 data recordings per second, and a target minimum of 300 data points per test are recommended. If a transition region or initial ply failures are noted, record the force, bearing strain, and mode of damage at such points. If the specimen is to be failed, record the maximum force, the failure force, and the bearing strain (or hole displacement) at, or as near as possible to, the moment of rupture.

NOTE 12—Other valuable data that can be useful in understanding testing anomalies and gripping or specimen slipping problems includes force versus head displacement data and force versus time data.

NOTE 13—A difference in the bearing stress/bearing strain or force/bearing strain slope between bearing strain readings when instrumentation is mounted on the opposite edges of the specimen as shown in Fig. 14 indicates in-plane (edgewise) joint rotation in the specimen.

11.5 *Failure Mode*—Record the mode and location of failure of the specimen or fastener/pin, or both. Note that the intention of this test method is to determine the bearing-dominated joint response and that evaluation of specimens that produce bypass failure modes is beyond the scope of this test method. Bearing stress results shall not be reported for specimens exhibiting lateral (net tension) or cleavage failure modes. Choose, if possible, a standard description using the three-part failure mode code shown in Fig. 29. A multimode failure can be described by including each of the appropriate failure-type codes between the parentheses of the M failure-type code. For example, a typical failure for a [45/0/−45/90_k]_{ms} tape laminate

having elements of both local bearing and cleavage might have a failure mode code of M(BC)11.

NOTE 14—The final physical condition of the test specimen following testing depends upon whether or not the test method was stopped soon after reaching maximum force. If the test is not so stopped, the test machine will continue to deform the specimen and disguise the primary failure mode by producing secondary failures, making determination of the primary failure mode difficult. In some cases it may be necessary to examine the bearing stress/bearing strain curve to determine the primary failure mode; in other cases the failure mode may not be determinable.

12. Validation

12.1 Values for ultimate properties shall not be calculated for any specimen that breaks at some obvious flaw, unless such flaw constitutes a variable being studied. Retests shall be performed for any specimen on which values are not calculated.

12.2 Any failure in a sample population occurring away from the fastener hole(s) shall be cause to reexamine the means of force introduction into the material. Factors considered should include the specimen alignment, fixture alignment (if appropriate), grip pressure, grip alignment, grip surface texture/quality, separation of fixture halves (if appropriate), specimen thickness taper, and uneven machining of specimen ends.

13. Calculation

NOTE 15—Presentation and calculation of results by this test method are based on normalizing total joint force and overall joint displacement to the response at a single hole. In the case of a double-shear test there is no adjustment necessary in either force or displacement. However, for a Procedure B single-shear test (assuming like specimen halves, and whether for one fastener or two), the total joint displacement is approximately twice the elongation of a given hole. For a double-fastener test, the hole force is one half the total force. This is the source of the k load factor and the K displacement factor used in the following equations.

13.1 *Width to Diameter Ratio*—Calculate the actual specimen width to diameter ratio using measured values with Eq 1, and report the result to three significant digits.

$$w/D \text{ ratio} = w/D \quad (1)$$

where:

w = width of specimen across hole, mm [in.], and
 D = hole diameter, mm [in.].

13.2 *Edge Distance Ratio*—Calculate the actual specimen edge distance ratio using measured values with Eq 2, and report the result to three significant digits.

$$e/D = (g + D/2)/D \quad (2)$$

where:

e/D = actual edge distance ratio, and
 g = distance from hole edge to specimen end, mm [in.].

13.3 *Bearing Stress/Strength*—Determine the bearing stress at each required data point with Eq 3. Calculate the ultimate bearing strength using Eq 4. Report the results to three significant digits.

$$\sigma_i^{br} = P_i / (k \times D \times h) \quad (3)$$

$$F^{bru} = P^{max} / (k \times D \times h) \quad (4)$$











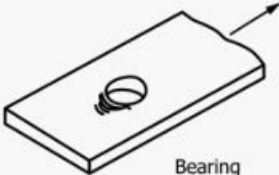

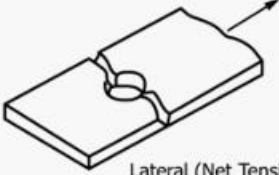
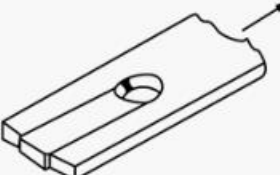
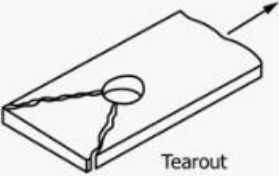

 Bearing	 Cleavage	 Lateral (Net Tension)	 Shearout		
B1I	C1I	L1I	S1I		
 Tearout					
T1I	D1I	P1B	Y3H		
					
Y3N	Y3T	E3H	E3S		
					
T3H	T3T	S3S	S3T		
First Part		Second Part		Third Part	
Failure Type	Code	Failure Area	Code	Failure Location	Code
Laminate Bearing	B	1 st Hole	1	Laminate Head Side	B
Laminate Cleavage	C	2 nd Hole	2	Laminate Nut Side	N
Laminate (lateral) Net Tension	L	Both Holes	B	Fastener Head	H
Laminate Shear-Out	S	1 st Fastener	3	Fastener Nut/Collar	C
Laminate Tear-Out	T	2 nd Fastener	4	Fastener Shank	S
Laminate Delamination	D	Both Fasteners	F	Fastener Thread	T
Laminate Pull-Through	P			Inapplicable	I
Fastener Yield	Y			Unknown	U
Fastener Bending	E				
Fastener Tension	T				
Fastener Shear	S				
Multi-Mode	M(xyz)				
Other	O				

FIG. 29 Bearing Test Failure Codes With Illustrations of Common Modes

where:

- F^{bru} = ultimate bearing strength, MPa [psi],
- P^{max} = maximum force prior to failure, N [lbf],
- σ_i^{br} = bearing stress at i -th data point, MPa [psi],
- P_i = force at i -th data point, N [lbf],
- h = specimen thickness, mm [in.], and
- k = force per hole factor: 1.0 for single-fastener or pin tests and 2.0 for double-fastener tests.

13.4 *Bearing Strain*—Determine the average bearing strain for each displacement value recorded using Eq 5 and report the results to three significant digits.

$$\epsilon_i^{br} = \frac{(\delta_{1i} + \delta_{2i})/2}{K \times D} \quad (5)$$

where:

- ϵ_i^{br} = bearing strain, microstrain,
- δ_{1i} = extensometer-1 displacement at i -th data point, mm [in.],
- δ_{2i} = extensometer-2 displacement at i -th data point, mm [in.] (for Procedure C, set $\delta_{2i} = \delta_{1i}$), and
- K = 1.0 for Procedures A, C and D, 2.0 for Procedure B.

NOTE 16—The K factors for two-piece tests may not be appropriate if the mating specimen-half is significantly different in bearing stiffness.

13.5 *Bearing Chord Stiffness*—Plot the bearing stress versus bearing strain data to produce the curve shown in Fig. 30. Calculate the chord stiffness between two specific bearing stress or bearing strain points in the essentially linear portion of the bearing stress/bearing strain curve (see Fig. 30 and Note

17). Bearing strain shall be the average of both extensometers, when two are used. Report whether bearing stress points or bearing strain points were used, as well as the value of the two end points.

$$E^{br} = \Delta\sigma^{br} / \Delta\epsilon^{br} \quad (6)$$

where:

- E^{br} = bearing chord stiffness, MPa [psi],
- $\Delta\sigma^{br}$ = change in bearing stress over chord stiffness range, MPa [psi], and
- $\Delta\epsilon^{br}$ = change in bearing strain over chord stiffness range, mm/mm [in./in.].

NOTE 17—The initial portion of the bearing stress/bearing strain curve will usually have substantial variations in the bearing stress/bearing strain response due to combinations of joint straightening, overcoming of joint friction, and joint translation due to hole tolerance. The chord stiffness points should be determined after this behavior has dissipated. Because of these variations it is often most practical to use bearing stress end points to determine the chord stiffness. The “essentially linear” portion of the bearing stress/strain curve may be quantified as that which varies less than 10 % from a linear approximation of the line.

NOTE 18—The bearing strain that is used for calculation of bearing chord stiffness shall be determined from extensometers installed in accordance with 11.4.6. Use of head displacement for this purpose is not recommended, as head displacement includes the effects of test machine and support fixture compliance.

NOTE 19—Bearing chord stiffness is used only for determination of the offset bearing strength in 13.8.

13.6 *Determination of Effective Origin*—Intersect the chord stiffness line with the bearing strain axis, as shown in Fig. 30,

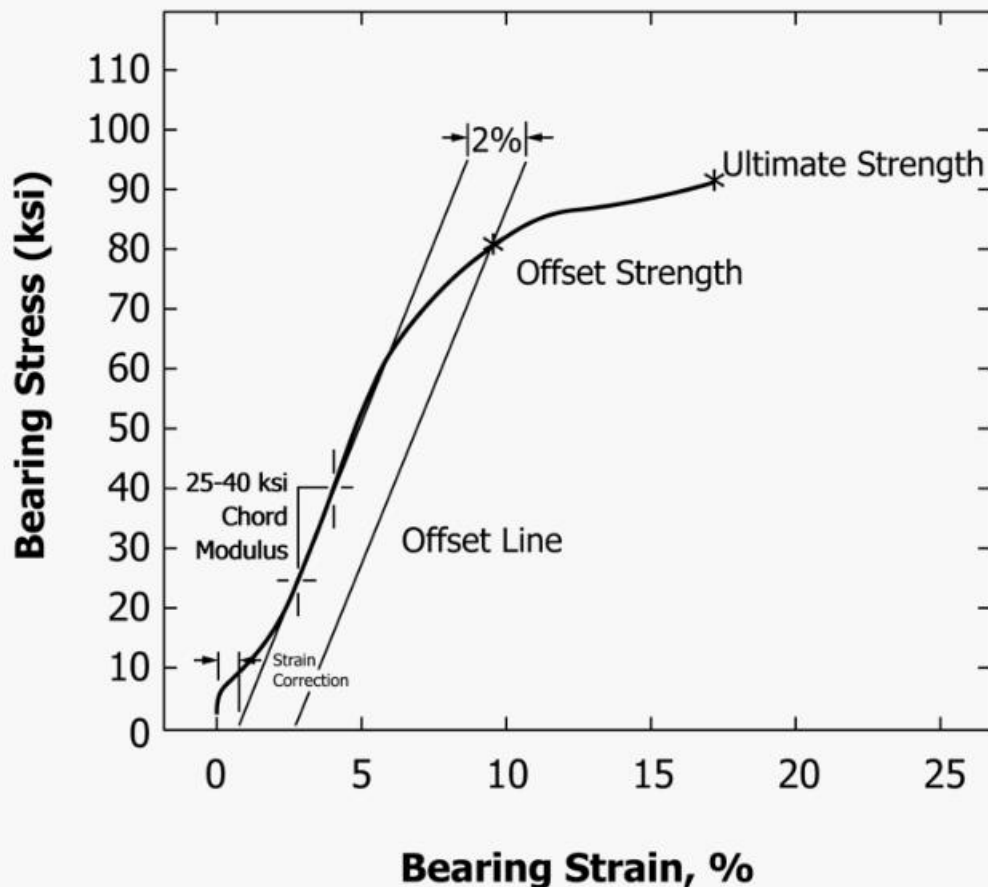

FIG. 30 Example of Bearing Stress/Bearing Strain Curve